

The Practical Guide to Reclamation in Utah

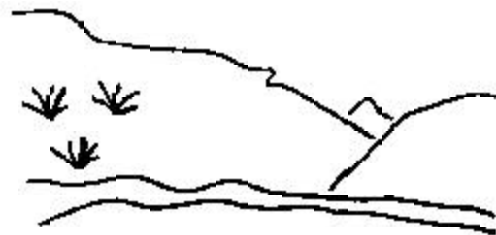

Utah Oil Gas and Mining

Contributors

Executive Editor

Mary Ann Wright

Technical Editor

Susan White

Contributing Writers

Paul Baker

Priscilla Burton

Robert Davidson

Sharon Falvey

Tony Gallegos

Randy Harden

Gil Hunt

Doug Jensen

Robert Krueger

Luci Malin

Dick Rol

Jim Smith

Mike Sufлита

Ken Wyatt

Project Coordinators - Edit and Design

Sharlyn Denison

Rachel Wilkins

Table of Contents

Introduction

Part 1: Reclamation Process

Chapter 1: Shaping Land

Section 1: General Concepts	6
Section 2: Visual Considerations	11
Section 3: Extraction Methods	16

Chapter 2: Reclaiming Waterways

Section 1: Drainage Reclamation	31
Section 2: Streambank Bioengineering	46

Chapter 3: Handling Soils

Section 1: Soil Salvage	54
Section 2: Soil Placement	64
Section 3: Problem Soils	71
Section 4: Erosion	78

Chapter 4: Revegetating Disturbance

Section 1: Revegetation Plan	87
Section 2: Application	93
Section 3: Success Techniques	98

Part 2: Technique Sheets

Technique Sheets

Section 1: Extreme Surface Roughening	106
Section 2: Vegetation	108
Section 3: Mulch	111
Section 4: Erosion Control Matting	116
Section 5: Slope Shape	119
Section 6: Vegetative Filter	121
Section 7: Straw Bale Barrier	122
Section 8: Silt Fence Barrier	126
Section 9: Temporary Diversions	130
Section 10: Temporary Slope Drain	132
Section 11: Outlet Protection	134
Section 12: Inlet Protection	136
Section 13: Check Dam	137
Section 14: Temporary Sediment Trap	141
Section 15: Sediment Ponds	143

Resources

Section 1: Maps	150
Section 2: Activity Checklist	158
Section 3: References	159

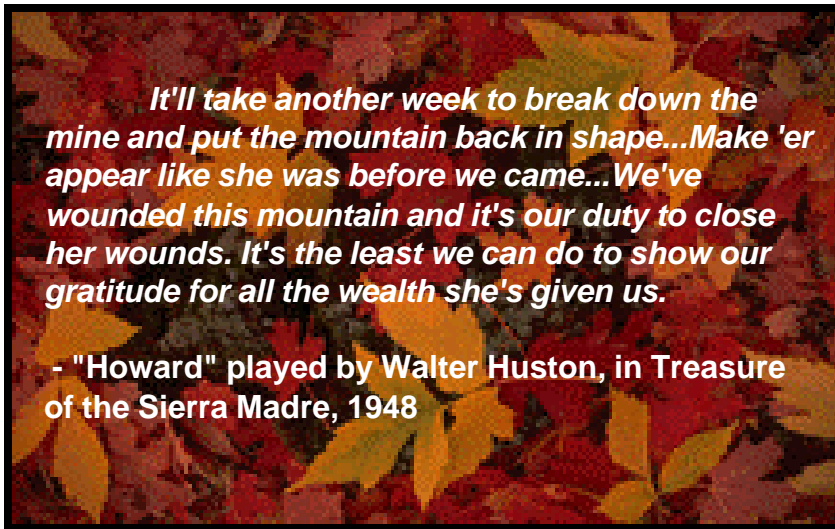
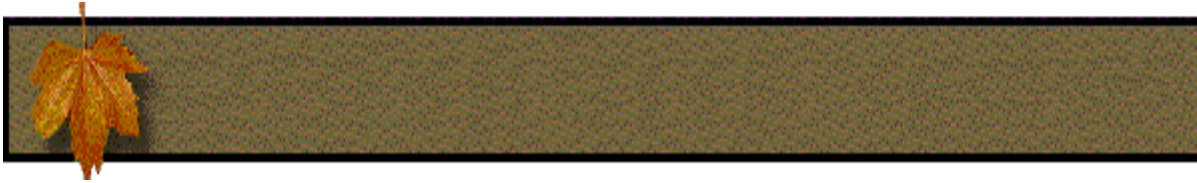

Introduction

The beginning of the new millennium marks 25 years of mining regulation in Utah. Since its start, reclamation of mined lands has been both 'trial and error' and heavily reliant upon application of existing technologies for restoring game range, or seeding after wildfire and other land disturbances. In this 25 years, hundreds of diverse mined land disturbances have been restored and reclaimed by mine operators and by agency effort cleaning up abandoned and bond-forfeited mines. At every site, some lesson was learned about how the next site could be done better. This manual represents an attempt to capture the very best methods which have been successful on the ground. The work, the successes, and the failures have all helped to write this guide. We hope you will find this collective learning experience of use in reclaiming your mine site.

How This Guide is Organized

This reclamation guide has two Parts. The first part, with four chapters, is written in progressive steps of the reclamation process from Shaping Land to final steps of Planting. Part 2 of this Guide has 15 Technique Sheets which can be used as stand-alone Best Management Practices. These were designed to be used in a variety of ways, including inserting them into Mine Plans or handing to contractors.

Your Part in This Publication

This guide is being presented electronically for ease of updating, cost containment and distribution. It is a living document subject to revision as a result of your input. Please help us to make it an even better resource as time goes on.



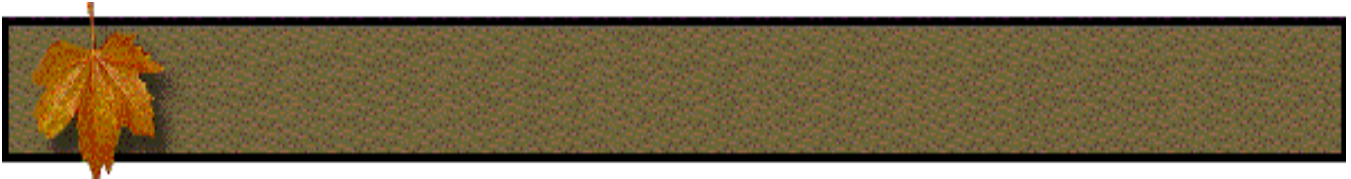

Chapter

1

Shaping Land

- **General Concepts**
- **Visual Considerations**
- **Extraction Methods**

General Concepts

Earthwork and grading (or land shaping) in the reclamation phase of mining must take into account that the land will have been disturbed twice, once in the mining phase and again in the reclamation phase. Major disturbances to land creates complex reactions involving the geology, hydrology, soils, vegetation, land use, and the visual and aesthetic values of the mine area.

Top concerns during earthwork and grading are safety and erosion. Stabilization of the mine area prior to and during earthwork activities will help eliminate failures as a result of land form changes. Secondary concerns are:

- Visual quality of the mine and adjacent areas
- Wildlife habitat loss
- Degraded water quality
- Altered drainage patterns



Figure 1.1: Major mining disturbances will affect visual and aesthetic values. Bingham Pit, Kennecott Copper.

Keep the following ideas in mind to plan mining and reclamation operations:

1. Planning Reduces Costs

Begin with the end in mind. Minimizing the amount of land excavation and alteration during mining operation yields a cost benefit as well as lessening the impact to the environment. Earthwork (backfilling and grading) accounts for up to 90% of reclamation costs. Plan carefully in the design and mining phases to handle materials once or as little as possible. Backfilling done at the end of mining can be the most expensive reclamation technique. Also, mistakes made during mine development and operation phases often compound themselves during the reclamation phase. The best way to minimize grading impacts is by minimizing grading itself. Grading to avoid geologic hazards can be reduced by working with an



Figure 1.2: A hilfiker wall is used to construct a substation, reducing land disturbance. Dougout Mine.

engineering geologist or project engineer to develop sitespecific stabilization techniques. Efforts to minimize grading for a site may require modifications to the project design or scale of development.

Access Roads

The biggest disturbance to many sites can come from the required road access ([Chapter 3, Section 4](#)). Most local governments have developed standards for roadway widths, grades, curve dimensions, etc., which are intended to provide safe access to the site for regular vehicles and emergency equipment. Significant site alteration is often required to meet these standards.

As with many concerns, two mutually compatible approaches are:

- Carefully plan and consider access early in the planning process.
- Explore ways to design roads to minimize grading for transportation and haulage equipment that will be used in conjunction with mining operations.

Excess material

Disposal of excess material can increase surface disturbance. If the project only requires removal of material, or making a cut, then careful dispersal of excess material on-site will not only avoid transportation costs, but can aid in later reclamation. Onsite disposal, however, can cause site impacts by disturbing additional area and possibly covering productive habitat with the excess material. This can create a new source of sediment and may cause water quality degradation if the excess material is not protected from drainage and runoff ([Part 2](#)).



Figure 1.3: A gold heap leach operation will generate large amounts of excess material. Goldstrike Mine.

Pits

Deal with pits during the mining phase. State regulations prohibit the impoundment of water in pit areas at the end of mining. Mine planning should address pit elimination during mining to lessen the operator's financial impact for having to close an impoundment at the reclamation phase ([Chapter 1, Section 3](#)).

2. Stabilize Your Site

Engineered structures may be needed for completing the mining and reclamation process. There are many engineering techniques to solve stability problems. Complicated stabilization should be completed by a certified engineering geologist and a registered professional engineer.

Simple methods of stabilization involve:

- Extensive grading
- Slope alteration
- Hazard removal
- Soil stabilization

Choose the method of stabilization based upon evaluation of the type of hazard involved, magnitude of the problem, potential triggering mechanisms, threat to life and property, and cost.



Figure 1.4: Wire mesh and gunnite stabilize the slope during the operation phase of mining. SUFCO Mine.

Slope alteration is a method of stabilization that involves variations of the cut and fill technique. The stability of a slope is increased by reducing the driving forces (unloading or removing the top of the slope) and/or increasing resistant forces (placement of fill at the toe of the slope) along potential failure surfaces.

Soil stabilization and soil improvement methods increase the load carrying capacity of soils by physical or chemical alteration of the soil. Soil improving and stabilizing techniques include:

- Reinforced earth
- Geosynthetics
- Grouting
- Chemical treatment

These improvements result in changes in soil properties of increased strength, stiffness, compressibility, cohesion, and improved ability to handle runoff and precipitation.

3. Protect Your Site from Runoff

Establish control of surface runoff and groundwater systems. Maintain water control through installation of surface and subsurface drainage devices within and adjacent to potentially unstable slopes. In landslide areas, drainage design is especially important. Control of surface and groundwater flow is also important in



Figure 1.5: Diversion at top of slope during mining phase will direct water away from the slope. Failure to maintain the diversion will result in breaching and failure making these structures unsuitable for the reclamation phase. Hidden Valley Mine.

minimizing erosion and siltation both on and off site. A properly designed drainage system should increase slope stability and decrease erosion and siltation.

Runoff and infiltration of water along a slope, or over a large cut face, can often be reduced by planting vegetation on top of the slope or cut, as certain types of vegetation anchor soils, which in turn reduces erosion. A vegetative cover that does not require irrigation must be chosen because the infiltration of the water from irrigation can result in increased failure potential. Revegetation will be ineffective in stabilizing slopes where movement has already begun.

Surface drains and/or landscape design are used to direct water away from the head and toe of cut slopes and potential landslides. This will reduce infiltration and erosion in and along a potentially unstable mass. Surface drains are instrumental in controlling erosion of slopes and in drainage control adjacent to fill slopes. Surface water control on sites that are already developed may require construction of drains or paving of areas to direct water away from slopes or a bluff. In these situations, the only available drainage control may be to contain and redirect runoff away from the face and through channels or pipes that extend to the toe of the slope.

4. Keep Drainage and Erosion Structures in Good working Order

Set up inspection and maintenance schedules for any installed structures such as silt fences, drainage pipes, culverts, etc. These structures can clog, pipes can corrode or rupture, or otherwise fail and may lead to slope damage or failure, structural damage or the need for extensive remedial grading. The long-term effectiveness of a particular engineered structure can be increased dramatically by developing and implementing specific maintenance procedures. If damage is noted on an inspection, complete any repairs prior to the start of the next rainy season. Additional inspections should follow any large storm event.

5. Keep Slope Safety Requirements in Mind

Safety regulations, both state and federal, do not allow for establishment of highwall (the face, or open cut of exposed overburden and mined material) slopes greater than 45°. Because of the instability of some geologic horizons, a 45° slope may be too steep. Pay attention to the geologic stability when planning reclamation and mining activities. Professionals may be required for this. Regulations have been put in place to provide a safer environment for workers and equipment and for downslope users, be they residential, recreational, agricultural or commercial.

In nature, soil can exist on a rather steep slope due to natural cementation and compression during formation. But, once an area is graded or excavated, then engineered codes or standards will dictate what slopes and drainage configurations are necessary to maintain safety. These codes or standards have been developed from years of experience and observation of what seems to be effective ways to create safe slopes.

6. Try to Achieve Natural Slopes

While keeping safety requirements in mind, unimaginative application of safety standards can lead to a very orderly and unnatural looking landscape. The visual result of

regularly spaced terraces and down-drains, with runoff diverted into controlled channels, is very stark and the dramatic relief is so extreme as to be undesirable. In addition, natural vegetation that had existed at the mine previously may not establish well on designed slopes.

It is better to apply imagination and variability in the slope design to achieve a natural landform while adhering to engineering requirements. The common regulatory term for achieving a natural landform is called "Approximate Original Contour (AOC)". Specific AOC requirements apply to different commodities mined, but the concepts for earthwork and grading are the same.



Figure 1.6: Minor drainages and ridge lines should be continued from the undisturbed into the disturbed area. Sunnyside Mine.

Natural looking topography can be achieved early on throughout the mining process by:

- A well planned extraction operation
- Having equipment operators fully understand the post-mining use of the site. Natural slopes can also be formed by mining to the prescribed safety angles, or by the cut and fill method. This is generally the most inexpensive means of reclamation.
- To re-create a natural land form, a pre-mining slope inventory is the most helpful. Pre-mining topography maps should be the same scale and contour interval as the post-mining contour maps ([Resources](#)). Pre-disturbed areas, with no available pre-mining maps, can be graded to natural land form by studying adjacent slopes and topographic features.

Visual Considerations

Though biological, chemical, and geological concerns are important, the way a reclaimed landscape looks is often equally significant to the public. This section discusses the components of visual character and how it can be used to create aesthetically appropriate reclaimed landscapes.

Attributes of Visual Character

It is important to effectively shape reclaimed mining lands so that they appear natural. This requires an understanding of how humans perceive landscapes. The four most important attributes of a scene's visual character are form, line, color, and texture.

Visual Attributes

- **Form** refers to the overall shape of a landform. For example, tailings piles, with even side slopes and flat tops usually contrast sharply with surrounding natural landscape forms (Figure 1.7).
- **Line** is closely linked to form, but refers to a single, linear element in the landscape as opposed to the overall form of an object. A tailings pile often has a distinct edge at the interface between the side slopes and the top of the pile. The edge forms a prominent line in the landscape. Naturally occurring lines include ridgelines, avalanche chutes, streams, and exposed geologic strata. Lines that occur in natural landscapes are usually not straight.
- **Color** can help an object or landform blend into its surroundings or draw attention as a prominent feature. Color in a reclaimed landscape is created by soil, rock material, and growing vegetation. It is important to closely match soil, rock, and vegetation to those in adjacent areas.
- **Texture** is influenced by color and shadow differences. The presence of irregularities, scattered rocks, vegetation patterns, and micro-variations in topography all create texture. In many areas of Utah, slopes are strewn with boulders of various sizes. Reclaimed slopes, no matter how well they blend in form, will be conspicuous if they are lacking the texture created by such scattered boulders. The same is true of texture differences created by a lack of proper surface roughening or an overly simple and even distribution of vegetation.



Figure 1.7: Form and color dominate this view of a series of very large waste rock piles. Kennecott Copper.

Characterize the Surrounding Landscape

Begin land-shaping efforts with a visual survey of the surrounding landscape. Conducting a survey will increase your chances of producing a more natural look when finished. The survey should include information about slope, vegetation, water, and other outstanding features.

- Slope-include length and percent grade, presence and characteristics of natural benches and the slopes shape (concave, convex, uniform, or complex), spatial relationship to other landscape features, and the presence, frequency, and size of boulders.
- Vegetation- included species composition, overall colors (which may vary with season), density of cover, and patterns as they vary with slope, elevation, aspect, or other variables.
- Water-include drainage configuration and patterns, wetlands and ponds, and floodplain terraces.
- Other outstanding features-include cliffs, exposed geologic features, and scree fields.

A large part of creating a natural-looking reclaimed landscape is to make sure the expected components of the landscape, such as vegetation, rocks, and water, are present. The remaining effort involves appropriately arranging and configuring those components.

Analyze the Viewshed

Analyzing the conditions by which the mine is viewed will often provide useful insights toward developing an aesthetically pleasing landscape. For larger, high profile projects, this process may be a requirement mandated by law or demanded by the public.

Be sure to answer the following questions when analyzing the viewshed:

1. From what areas can the mine be seen? This task is frequently accomplished by standing at the mine site and simply noting what parts of the landscape are visible. The projects viewshed is the places that are visible from mine.
2. Who are the viewers? Viewers' attitudes toward scenery will vary considerably depending on their values. For instance, a tall quarry highwall may be seen as beautiful by the residents who make their living from operation, whereas the same highwall may be dangerous by a mother of small children, or as an ugly environmental problem by a passing tourist.
3. Where are the viewers? Is the mine visible from places where large numbers of people live or gather? Is it visible from scenic byways or overlooks? Does the position of the viewers provide opportunities to frame or hide certain aspects of the project?
4. What is the viewing distance for most viewers? The focus of the visual aspects of reclamation may change depending on the distance from which the area is viewed. Distant views are dominated by landscape form, but form may take a back seat to texture and color in near views.
5. What is the duration of view for most viewers? The amount of time a viewer has to scrutinize a view may affect the reclamation strategy. Motorists, traveling past a project at highway speeds, will not have time to scrutinize the details of a project. However, a resident of a nearby town will.

The combination of answers from these questions will provide guidance for the creation of a reclaimed landscape that is responsive to the needs and concerns of the viewers.

Application

Mining operations create regular features in an irregular landscape. Waste piles, tailings piles, highwalls, benches, terraces, and road cuts are examples. They all introduce a combination of straight lines, smooth slopes, and rectilinear forms in the landscape. When a natural-appearing reclaimed landscape is a goal, those features must be broken up and blended with their surroundings.

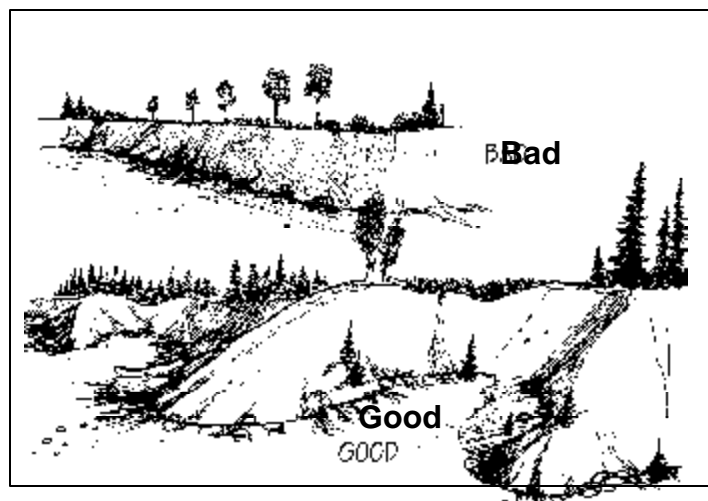

Figure 1.8: Reclaimed slopes should be curved and irregular in both plan and profile. (Taken from Norman et. al., 1996)

Road cuts can frequently be reclaimed simply by using fill material on the downhill side of the road to fill in the bench created for the road. Visually, the important aspects are to match the contour of the hillside without abrupt changes in grade, and to match adjacent vegetation and geologic characteristics as close as possible.

Breaking up straight lines and long straight slopes simply involves responding to adjacent landforms. Most of these features can be removed, covered, or regraded to make them blend effectively with their surroundings. When dealing with unconsolidated materials such as waste and tailings piles, the straight slopes should be graded to respond to the contours of the area. Generally, the reclaimed slopes should be curved and irregular in both plan and profile (Part 2, Section 5). Continue ridgelines and drainages that pass through the project area and create small depressions and hummocks within the reclaimed slopes to enhance their natural appearance. Though reclaimed slopes must be graded to stable angles, interspersing occasional steeper sections will also help the slope blend with its surroundings.



Figure 1.9: Both photos show reclaimed slopes. The left photo shows irregular topography, scattered boulders, and a patchy vegetation pattern that help the slope blend with its surroundings. (UP&L Carbon Plant) However, none of the same attributes are present in the photo to the right, causing the slope to contrast sharply with its natural surroundings. (Royal Coal Pile).

Occasionally, well-intentioned reclamation efforts will result in the creation of new artificial lines in the landscape. Perfectly straight project boundaries with abrupt or sharp change in grade and drastically different vegetation, rocks, or soils emphasize the difference between natural and reclaimed terrain. To avoid these problems:

- Feather the edges of the project in a more sinuous line to blur the transition between natural and reclaimed terrain.
- Create smooth, rounded grade transitions where the reclaimed contours meet grade.
- Replicate natural surface conditions as closely as possible. In forested areas, cluster trees and shrubs randomly and create a height transition at the perimeter of the disturbed area to help blur the line between natural and reclaimed.

Highwalls and terraces constructed in consolidated rock are more difficult to disguise than many other mining features. Reclamation blasting can be used to create chutes, spurs, scree slopes, and rough cliff faces on these sites. Strategically placed charges will break up sections of the cliffs and benches and produce slopes of loose rock, resulting in a more natural-appearing cliff face. As with other reclamation practices, create landforms that relate and blend with those found naturally in the area.

The reclamation specialist must become familiar with reading the visual landscape and be proficient in translating those observations into a reclamation strategy appropriate for the project's unique landscape. Create what you see around you.

Additional Details

Proper shaping of the reclaimed landform is only the first step toward an aesthetically pleasing reclamation project. Pay attention to color and texture after shaping efforts have been completed. Use plants, rocks, and other natural materials to match the reclaimed surface with the surrounding natural areas. In some cases, grubbed trees and brush can be reapplied to recontoured slopes to provide desired initial texture. Plant trees and shrubs randomly or in clusters rather than in uniform rows. Opportunities for other innovative strategies may present themselves during the course of a project.

Extraction Methods

Heap Leach

Heap leaching involves percolation of solutions through low-grade ore for recovery of metals. Leach solutions are typically cyanide or sulfuric acid. These chemicals are used primarily to recover gold, silver, and copper. The ore to be leached ranges from run-of-mine materials, which undergo no crushing or screening, to ore which has been crushed, and/or agglomerated. The ore is placed on a leach pad that sits on top of a liner commonly made of a synthetic material or a combination of synthetic materials and clay. Several examples of leach pad systems are heap leach, valley fill leach, on-off pad leaching, or vat leaching, depending on the physical characteristics of the leach pad. Ore to be leached is placed on the liner in lift thickness ranging from ten feet to several hundred feet. Leaching normally takes place as each lift is being placed on the pad. The solution percolates through the pile, dissolves the metals and collects at the base of the pile. This pregnant solution from the plant are circulated to barren ponds. The solutions in the barren

agglomeration: Adding a minor amount of a cement or lime mixture to the ore to improve the physical strength of the ore and crushed material to improve the percolation of solutions.



pond are checked for chemical levels and if the levels are sufficient, the solutions are then reapplied to the material on the leach pad.

Figure 1.10: The ore is placed on a liner and the solution percolates through the pile. Goldstrike Mine.

Possible leaching operations facilities:

- one or more lined leach pads
- a lined pregnant pond
- a lined barren pond
- a lined overflow or makeup water pond
- solution management facilities
- pipeline networks
- metal extraction facilities
- reagent storage areas in addition to structures and facilities associated with mining operations

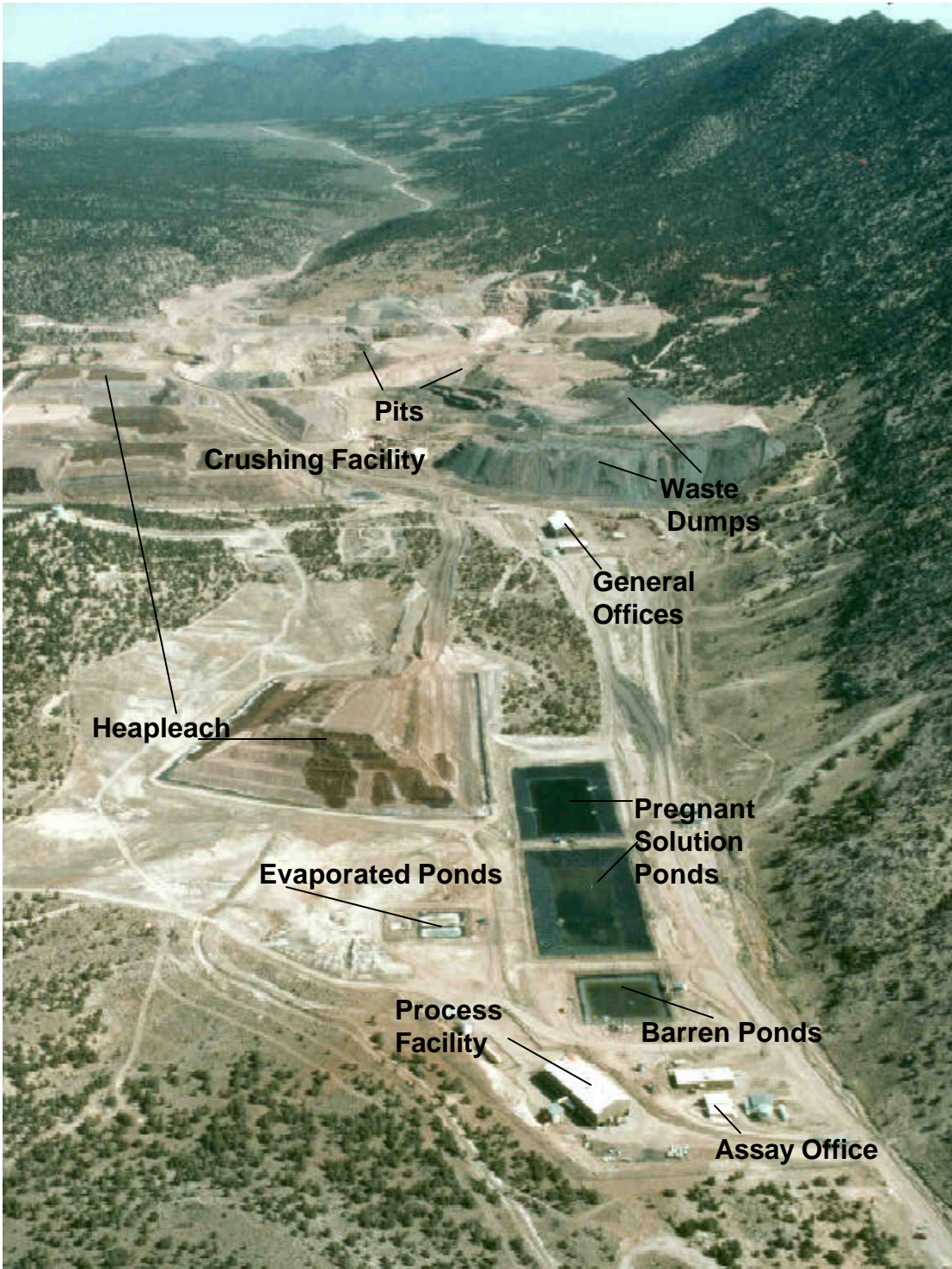
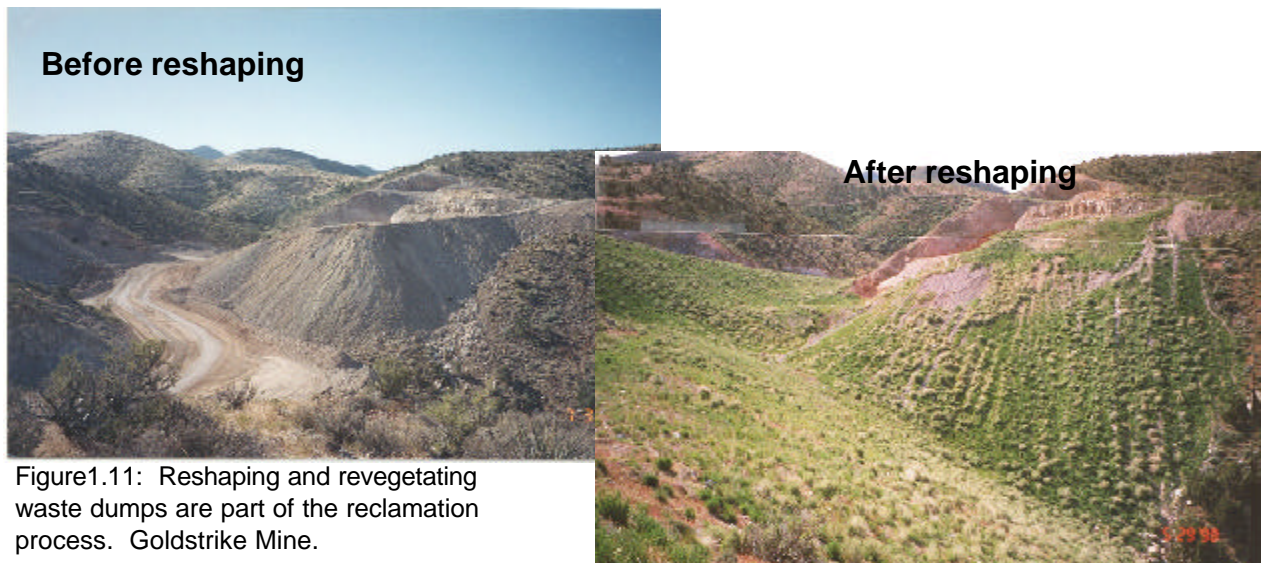

Figure 1.12: Typical facilities at a leach operation. Alagator Mine.

Tasks for reclamation of leach operations:

- neutralization or rinsing of the leached ore
- extending liners, if necessary
- reshaping the rinsed ore
- capping the leached ore
- revegetation of the reclaimed mine site
- management of pad solutions during reclamation
- land application of excess solutions (approval of this option is dependent on solution analyses)
- evaporation of excess solutions
- solution management after reclamation
- removal of structures and facilities and reclamation of the areas
- characterization and appropriate disposal of pond sediments
- regrading and reclaiming pond areas
- regrading and revegetating access roads.



Possible complications in reclamation:

- toxicity of the leached ore
- inability to neutralize the leached ore
- liner failures
- instability of leach dumps
- drain down solutions which exceed standards
- excessive solutions

Rinsing and Neutralizing

If possible, the rinsing and neutralizing of the leached ore should take place in gradual phases during active operations to help defray costs of reagents and solution handling. Operations with multiple leach pads may be rinsing or reclaiming leach pads while still actively leaching other leach pads. Rinsing may take months or years to complete, and best results can be achieved through a series of rinse and rest cycles. Rinsing could be as simple as applying fresh water through the distribution system or as complex as treating the heap with a chemical solution and running the recovered solution through a neutralization circuit. The solutions that come off the lined areas must meet the standards of the agency regulating surface or groundwater at the site before the leach pad material can be considered rinsed.

Grading

The rinsed ore may require grading to achieve a more desirable configuration prior to capping and revegetating. During initial operations, the ore should be placed on the pad in a configuration which minimizes grading during final reclamation. Final reclamation should be considered when the leach pad is initially engineered and designed. A slope angle of three horizontal to one vertical (3H:1V) or less is desirable from a revegetation standpoint. This slope angle will also be accessible for most heavy earth moving equipment. However, a slope angle greater than 3H:1V may be considered to minimize the surface collection of precipitation and reduce slope length. These opposing concepts should be balanced against the long range reclamation success of the



Figure 1.13: Heap leach operation prior to grading. Goldstrike Mine.



Figure 1.14: Heap leach operation after grading. Pits are backfilled and leach pads reshaped to blend into surrounding topography. Goldstrike Mine.

feature. Regrading the slopes of leached ore may or may not require the extension of synthetic liners below the regraded materials. This will depend on the constituent levels of the pad material and the view of the regulatory agency. Slope configuration will contribute to successful revegetation, stability, and minimized infiltration. Interim measures may be required to handle precipitation until the reclaimed surfaces have sufficient vegetation to prevent erosion.

Capping

After the leached ore is regraded, the ore may require the placement of an engineered cap if the leached ore is toxic. The cap design may include a clay or synthetic liner, a capillary barrier, subsoil and topsoil, or armoring. The physical characteristics and toxicity of the leached ore will dictate capping design. The more complex the cap design, the more expensive the reclamation. Sampling and analysis of the leachate effluent and pad material will be used to design the cap. The regraded ore surface should be left in a rough condition to improve stability and cohesion between the ore and cap or soil layer. The cap design for non-toxic ore includes a subsoil layer covered by a soil layer. A capillary break is often desirable between the ore and subsoil layers. A soil depth of 12 inches or more is desirable, but the characteristics of the subsoil may allow a shallower depth of soil. The final surface should have surface roughness to improve retention of seed, and soil, while minimizing erosion. The rough surface will also increase the water retention from precipitation. This surface roughness may increase retention and infiltration of precipitation until a sufficient amount of vegetation has grown. These opposing concepts of water retention versus water shedding will need to be weighed based on the site-specific conditions.

Solutions Management

During reclamation and after completion of the seeding, the leached ore will continue to produce solutions. The volume of solutions will generally decrease over time. These solutions must be collected, analyzed, and retained or disposed. The actual handling of these solutions will be driven by their analysis and volume. Water management may be as simple as creating a passive infiltration system or as complex as retention and treatment of the solutions. Other options include passive or aggressive evaporation, land application, or passive treatment through a bioreactor system. Water management may require ongoing sampling and analysis. The duration of sampling and analysis may be short-term or long-term, depending on the site conditions, chemistry of the water, and decisions of regulatory agencies. Facilities that must remain for solutions management will require reclamation after satisfying release criteria. Post-mining solutions management facilities should be designed with final reclamation in mind.

Post-Closure Monitoring

The leaching operation will require monitoring after reclamation has been completed until the site is released. Reclaimed leach pads must be examined for signs of instability, poor vegetation success, and toxicity. The post-closure solutions management system will need to be maintained. Solutions will need to be sampled and analyzed according to the protocols of the regulating agency. In Utah, the main regulatory entity dealing with leach pad design and solutions management is the State Division of Environmental Quality.

Tailings

Mine tailings are the materials that were not retained during ore processing. Tailings materials are usually small in particle size, may contain concentrations of undesirable metals, residue chemicals, and a considerable amount of water. Reclamation of tailings facilities includes dewatering, and revegetating. Mine tailings are typically transported as a slurry mixture by pipelines to an impoundment area. Tailings materials may be deposited into the impoundment area at a single point or multiple points. The method of discharge will directly influence the depositional geology, which in turn affects

the structural stability of the tailings impoundment. A common problem with reclamation of tailings is instability due to the high moisture content of the fine grained materials. This instability limits the use of heavy equipment on the surface of the tailings. Initial stabilization of tailings is focused on dewatering. Dewatering practices range from the passive treatment of allowing upper layers to dry out over a long period of time to a more aggressive approach of installing underdrains, horizontal drains, and vertical wick drains. The handling of tailings streams to create a paste material is another method of increasing stability of tailings. Paste technology may be utilized during initial deposition of tailings or later in the project life to construct features on or in the tailings impoundment. The toxicity of the tailings may complicate the reclamation process by requiring neutralization and placement of an engineered cap. The purpose of the engineered cap may be to prevent infiltration of moisture, to prevent oxidation of the tailings, or to prevent the escape of radon gas. The solutions recovered from the tailings during reclamation will need to be managed. The solutions may require treatment or simply collection.

capping: To amend or provide physical barrier to undesirable properties of tailings.



Figure 1,15: Tailings embankment construction. Kennecott Tailings Facilities.

Dewatering

Dewatering is best accomplished during active operations to spread the costs over a longer period of time. Tailings water is ordinarily decanted from water separated from the tailings within the impoundment. A floating barge is commonly used to remove this water. If the operation has the luxury of an extended period of time, the tailings may be allowed to dry out naturally. This passive solar method may not dry the entire depth of tailings, depending on the characteristics and thickness of tailings.

One common method of actively dewatering the tailings is to push vertical wicks into the tailings deposit. These wicks allow vertical flow of solutions between various layers of tailings at depth. Placing a large number of these wicks close together can create a chimney drain effect. During dewatering, the upper surface of the tailings may dry out quickly while the lower layers remain wet for a longer time period. In this case, dust control techniques may be required during the interim until the tailings can be capped and revegetated.

Capping

The more complex the cap design, the more difficult the actual installation. Placement of capping materials may require the use of low ground pressure equipment and a variety of placement techniques. Techniques may include the placement of capping materials using a track hoe or back hoe on synthetic liners placed on the tailings. These materials are used to construct a ramp or finger dike out onto the tailings to create a working surface. This ramp will probably experience a large amount of settling requiring placement of several lifts before supporting heavy equipment. A wetting front is often formed ahead of this ramp, due to the water being squeezed out of the tailings by the loading. After the ramp is constructed, additional capping material can be placed from the ramp to gradually increase the capped area.

Another technique is to construct the ramp as a dike around an area to create an isolated cell. The dike enhances dewatering of the area and provides a platform from which capping materials may be placed. This cell can then be used as a construction platform to construct another isolation dike.

Sampling and characterization of the tailings material may provide some information describing the physical properties of the tailings. But most operators still have to resort to trial and error attempts to determine which method of cap construction will work and how fast the work may proceed.

The most commonly used capping material is waste rock from the mining operations, although an engineered cap may require very specific capping materials such as clay or synthetic liners. A capillary barrier or capillary break may be needed in the cap design to prevent plant roots from penetrating into the tailings materials. A capillary barrier may also be utilized to minimize oxidation of tailings below the barrier. A capillary barrier is created by placing fine grained material over larger grained material. The capillary action of the fine-grained material prevents moisture from flowing through the coarse material into the tailings.

Capillary barrier:
Air spaces which prevent movement of water.

Some tailings materials may be suitable for revegetation. These tailings may be seeded directly as soon as they are stable and may require the addition of minor amounts of organic materials such as mulch, composted manure, or biosolids.

It may be more cost effective to treat the upper layers of tailings to neutralize contaminants or increase the organic content during active operations than to wait until afterward. The treatment materials may be added directly into the tailings stream during the entire operation or during the last years of tailings placement to create the desired capping mixture in the top layer.



Figure 1.16: A dike is used to isolate the tailings cell. Seed is placed into amended tailings. Kennecott Tailings Facilities.

Revegetation

The combined depth of the subsoil and soil layer will need to be sufficient to support vegetation alone if the tailings material is inhospitable to plants. This subsoil layer may range in thickness from several inches to several feet. An engineered cap may be required in addition to the subsoil and soil layer.

For tailings materials which are not hostile to plants, direct seeding into the tailings several years in advance of final reclamation may help dewater the upper surface, aid in dust control, and increase the organic content of the tailings.

The final surface of the reclaimed tailings area should be graded to divert surface water off of the tailings. The surface should be roughened to enhance seed and moisture retention for vegetation success. Interim measures may be needed to minimize erosion from precipitation until vegetation starts to grow. These interim measures may include the application of a tackifier or mulch during the first growing seasons ([Part 2, Section 3](#)).

Plugging and Abandonment



Figure 1.17: A well is plugged after operations have ceased.

The owner or operator of an oil, gas, or injection well should consider plugging and abandoning a well when it:

1. Is no longer capable of safe and environmentally sound operations
2. Becomes unprofitable to operate
3. Cannot be operated in accordance with Division rules or permit

Well plugging, abandonment and well site reclamation involves:

- Informing the Division with a proposed procedure
- Division review, comment, and approval of the procedure
- Plugging and reclamation work by the owner or operator
- Inspection by the Division
- Final inspection by the Division



Figure 1.18: Plugged and abandoned well marker.

Note: The Division may release a well bond when the proposed work is complete.

Well Status Requirements

In accordance with Rule R649-3-36 of the Oil and Gas Conservation General Rules, June 2, 1998 Revision, Shut-in and Temporarily Abandoned Wells, wells may be shut-in or temporarily abandoned for twelve months. If the well is to be shut-in or temporarily abandoned for over twelve months, the owner or operator must file a Sundry Notice 9, and provide all of the following information to the Division:

- Reasons the well is being shut-in or temporarily abandoned.
- The length of time that the well is expected to be shut-in or temporarily abandoned.
- An explanation with supporting data showing the integrity of the well. This includes information about the cement, casing, equipment condition, fluid level, pressures, presence or absence of underground sources of drinking water and other factors indicating the well does not pose a risk to public health, safety, or the environment.

The Division will review the Sundry Notice and either approve the status extension or require remedial measures be implemented to establish and maintain the integrity of the well.

An owner or operator of a Utah well that has been inactive or non-productive for over five years must either plug and abandon the well or provide a showing of good cause as to why the well should not be plugged. The Division may order a well to be plugged that has not established good cause as to why the well should not be plugged. In the event an owner or operator fails to comply with a Division plugging order, bond forfeiture proceedings may be initiated.

State Plugging Requirements

Sundry Notice of Intent

The State of Utah specifications for plugging and abandonment of regulated wells are contained in Rule R649-3-24. Prior to commencing field operations, the owner or operator is required to submit a Notice of Intent to the Division requesting approval for the proposed plugging procedure. The Notice of Intent must be filed on Form 9, Sundry Notice and Report on Wells. For wells located on Federal or Indian land, the operator must file with the Division an Approved Procedure/Notice of Intent on the appropriate Federal or Tribal form. The following information is required in the Intent Sundry Notice:

- Location and status of the well
- Description of the well bore configuration, indicating casing sizes and depths, cement tops, existing equipment, and completions
- Depth to the top of known geologic markers or formations
- Depths of coal or potash beds or oil shale zones encountered
- Any other information that may have a bearing in determining the adequacy of the proposed procedure

Plugging Procedures

The Division does not generally advocate one specific plugging technique or cementing method over another. The Division recognizes techniques as recommended by the American Petroleum Institute (API) as being acceptable for use in Utah. Division Rule R649-3-24, Plugging and Abandonment of Wells, establishes several specific requirements for fee and state lease wells.

Specific Requirements for Fee and State-Leased Wells

1. Bottom Plug--The bottom of the hole should be sealed with a solid cement or bridge plug.
2. Formation Isolation Plugs--100-foot solid cement plugs must be placed above each producing formation open to the well bore.
3. Perforated Interval Plug--Perforated intervals need to be plugged with cement.
4. Cut Casing Stub/Shoe Plug--If the casing is pulled, a 100-foot solid cement plug should be centered across the casing stub. In addition, a 100-foot cement plug must be centered across the casing shoe of the next larger casing string.
5. Fresh Water Zone Plug--A solid cement plug should be placed from fifty feet below to fifty feet above the fresh water zone; or, a 100-foot solid cement plug should be centered across the base and top of the fresh water zone.
6. Surface Casing Shoe Plug--A fifty-foot solid cement plug must be placed

from the base of the surface casing up the hole.

7. Open Hole Plug--Any porous section of open hole shall be isolated to prevent fluid migration.
8. Surface Plug--At least ten sacks (preferably 100 feet) of cement shall be placed at the surface to seal all annuli open at the surface. Acceptable techniques for filling surface casing annuli include perforation and circulation or filling bottom up with small-diameter tubing.
9. Plugging Fluid--The space between cement plugs within the well bore must be filled with a non-corrosive fluid dense enough to prevent water migration into or up the well bore.
10. Placement of Plugs--Cement plugs should be placed so that the well bore and all casing-to-casing and casing-to-hole annuli are completely sealed with cement. Mechanical devices should be used in accordance with the manufacturer's recommendation. Cement plugs placed without the conjunctive use of a bridge plug or cement retainer should be tagged to verify correct placement depth.

Subsequent Sundry Notice

The owner or operator is required to submit a subsequent report of the work within thirty days after completion of well plugging. Form 9, Sundry Notice and Report on Wells, includes:

- A complete description of the plugging work, including techniques used, cement characteristics, and depths.
- Records of any tests conducted and measurements made, such as pressure tests.
- A description of the amount, size, location, and depth of all casing left in the well.
- A statement of the amount of mud or plugging fluid used.
- A complete report of the method used and the results obtained for any attempts to part or salvage casing.

Well Site Restoration

Specific requirements for well site restoration in Utah are contained in Rule R649-3-34. For federal, Indian, or state surface ownership, the owner or operator shall meet the requirements of the appropriate surface management agency, such as the School and Institutional Trust Land Administration or the Bureau of Land Management. In the case of fee or private surface ownership, the owner or operator shall meet the well site restoration requirements of the surface owner, as stipulated in the surface use agreement.

In cases when no surface use agreement can be established, the Division shall establish minimum well site restoration requirements for the purposes of final bond release. The

Division's surface use agreement may state requirements for grading, contouring, reseeding, and abandonment of any equipment or facilities for which the landowner agrees to accept liability. The Division surface use agreement shall not address operations that are under the jurisdiction of the rules and orders of the Board of Oil, Gas, and Mining including but not limited to the disposal of drilling fluid, produced fluid, or other produced waste, or the reclamation or treatment of waste crude oil.

When establishing minimum well site reclamation requirements, the Division will follow the guidelines established in this manual.

Additional Sources of Information

As previously mentioned, API publishes numerous recommended practice manuals textbooks and other specific guidance for oilfield operations. References provided by API, the Society of Petroleum Engineers (SPE), and others that may prove to be useful with regards to well plugging and well site restoration include:

- Environmental Guidance Document: Well Abandonment and Inactive Well Practices for U.S. Exploration and Production Operations, API Bulletin E3, First Edition, January 31, 1993.
- Onshore Solid Waste Management in Exploration and Producing Operations, API, 1989.
- Worldwide Cementing Practices, API, 1991.
- Cementing, Dwight K Smith, Monograph Volume 4 of the Henry L. Doherty Series, SPE, 1976.
- Applied Drilling Engineering, SPE Textbook Series, Volume 2, 1991.
- Oil and Gas Surface Operating Standards for Oil and Gas Exploration and Development, United States Bureau of Land Management and the United States Department of Agriculture Forest Service, Third Edition, January 1989.

Waste Minimization

Historically, oil and gas exploration and production activities, also known as E&P, have resulted in large volumes of waste that had to be discarded. Wastes are generated at almost every level or stage of development, including drilling, processing, transportation, and storage. These wastes have been categorized as Resource Conservation Recovery Act (RCRA) exempt or nonexempt, according to the RCRA exemption for Exploration and Production Wastes. Some of the more abundant wastes are produced salt water, waste crude oil, tank bottoms, oily soils, pipe and tank scale, drilling mud, drill cuttings, and gas plant wastes such as spent glycol, filters, gas sweetening compounds, cooling tower



Figure 1.19: Oil well production site. Altamont - Bluebell Field Marker.

blowdown, and pigging wastes from pipelines. Today, 98% of the generated waste is produced water.

Waste Management

Over the past several years, changes in laws, regulations, and company



Figure 1.20: E&P waste facility. San Juan County.

perspectives have resulted in a more direct and preventive approach to waste management. This change has resulted from changes in technology, liabilities, and the rising costs of disposal. The new, preventative approach results in waste minimization. Companies are able to reduce costs through better management and waste minimization

during operations and at abandonment. Good waste management helps lead to lower cleanup costs when it is time to plug and abandon a well or close a facility such as a tank battery, compressor site, or gas plant.



Figure 1.21: Reserve pit containing drilling fluids.

Implementing Minimization Program

The potential benefits a company receives by implementing a waste minimization program include:

- Increased revenue
- Reduced costs of operating, materials, waste disposal, energy, and facility cleanup
- Improved operating efficiency
- Reduced regulatory compliance concerns
- Reduced potential for civil and criminal liability
- Enhanced public perception of the company and the industry as a whole

The Oil and Gas Conservation Act 40-6-5 UCA gives the Board authority to regulate the disposal of oil-field wastes. It is the intent of the Board and Division to regulate E&P wastes and facilities in a manner that protects the environment, limits liability to producers, and minimizes the volume of waste. Oil and Gas Conservation General Rule R649-9-2 requires each operator to file an Annual Waste Management Plan. A good waste management plan should include procedures and practices that result in waste minimization. In order to achieve the desired results, the focus of waste management must shift from the end of a process to the beginning. The first step in shifting the focus is for

individual waste generators to adopt the Waste Management Hierarchy of Preference endorsed in the federal Pollution Prevention Act of 1990. The overriding principle of the hierarchy is the reduction or elimination of both the volume and toxicity of waste that is introduced into the environment. From an environmental perspective, disposal is the least preferred option. To the extent practicable, waste management choices should be based upon the following hierarchy of preference, which range from the most preferred option to the least preferred option.

- Source Reduction
- Recycling
- Treatment
- Disposal

The American Petroleum Institute (API) and others have published guidelines for developing waste management plans that include minimization as an integral part.

At abandonment or closure, soils at a well or facility site must meet regulatory cleanup levels. The Division or other appropriate regulatory agency should be contacted for clarification of applicable cleanup standards. The Division must approve a plan for final closure of a disposal facility. Any reclamation carried out as part of the closure plan must take into consideration the post-disposal land use and landowner requests. This manual can also be used as a resource in reclamation techniques.

Additional References

API Environmental Guidance Document; Onshore Solid Waste Management in Exploration and Production Operations. 1989. 1st Edition, American Petroleum Institute, Washington, DC.

Clarification of the Regulatory Determination for Wastes from the Exploration, Development and Production of Crude Oil, Natural Gas and Geothermal Energy. 1993. 58 Federal Register 15284-15287.

Deuel, L. E. Jr. and H. H. George. 1994. Soil Remediation for the Petroleum Extraction Industry, PennWell Publishing Company, Tulsa Oklahoma.

DeVaull, G., et. al. Risk Based Corrective Action Tools for Exploration and Production Facilities. Gas Research Institute, www.gri.org.

Developing Area-Specific Waste Management Plans for E&P Operations. 1991. 1st Edition, American Petroleum Institute, Washington, DC.

Generic Hazardous Chemical Category List and Inventory for the Oil and Gas Exploration and Production Industry. 1988. American Petroleum Institute and the Independent Petroleum Association of America.

Guidance to Hazardous Waste Generators on the Elements of a Waste Minimization Program. 1993. 58 Federal Register 31114-31120.

Guidelines for Waste Minimization in Oil and Gas Exploration and Production. 1999. A Publication of the Interstate Oil and Gas Compact Commission.

Robb III, A., and P. Hoggatt. 1995. A Cost Effective Bioremediation Strategy Using Low Technology Resources for Reclamation of Dry Land Hydrocarbon Contamination: A Case Study. SPE 29759, 1995.

Shaw, B., et al. 1995. Microbes Safely, Effectively Bioremediate Oil Field Pits. Oil & Gas Journal.

Stilwell, C.T. 1991. Area Waste-Management Plans for Drilling and Production Operations. Journal of Petroleum Technology 67-71.

Utah Oil and Gas Conservation Act, 40-6-1 et seq. UCA 1953, as amended 1995.

Utah Oil and Gas Conservation General Rules, The. R649-1 et seq., amended June 2, 1998.

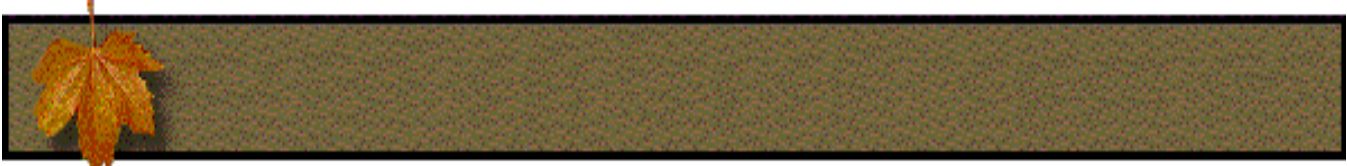

Chapter

Reclaiming 2 Waterways

- Drainage Reclamation
- Streambank Bioengineering

Drainage Reclamation

To achieve success in reclaimed mine sites, it is imperative to consider reclamation during the operational planning stage. Considering reclamation after the operational layout is designed results in difficulties in establishing appropriate landform and stream channel reclamation techniques. Considering reclamation during planning allows the operational layout to be built in a manner that will save time and money.

This chapter reviews many of the concepts presented in Stream Corridor Restoration Principles, Processes, and Practices, 1998, which can be viewed at http://www.usda.gov/stream_restoration. Begin initial reclamation planning with a channel layout. The overall channel grade is equal to the upstream and downstream elevation change where the upstream and downstream drainage ties into the existing drainage. Changes in the channel bed slope between these points should be designed based on the drainage characteristics that include the:

- discharge characteristics
- pre-existing channel geometry, geomorphology, and gradient
- post mining substrate or fill
- type and amount of bedload and sediment transported throughout the system
- postmining adjacent area topography



Figure 2.1: A road on the left and a railroad on the right of this channel dictated the channel design. Sunnyside Mine.

It is important to remember that the stream channel or drainage system has the potential to move both laterally and vertically. The existing and created drainage characteristics will effect the rate and extent that lateral and vertical erosion or deposition occurs.

Note: The channel elevation determines the lowest point on the regraded mine site, affecting the adjacent area configuration and elevation.

Where appropriate, it can be advantageous to maintain or reconstruct the pre-disturbed channel characteristics. In areas where it is necessary to reconfigure the drainage, existing natural gradient controls such as competent bedrock outcrops and the upstream and downstream channels should be utilized in determining the channel bed elevations.

A person familiar with fluvial processes should design perennial and intermittent channel reclamation, in addition to channels adjacent to important or sensitive water resources. Familiarity with geomorphology, channel and meander geometry, and the natural tendencies for channel adjustment toward stability is needed to predict the most effective design for long-term stability and function.

In ephemeral systems it is important to re-establish drainage density. Drainage density includes minor water pathways and swales that concentrate water and flow into the channels. This will minimize the erosion that would occur to establish a drainage density, which is in equilibrium with the reclaimed system.

Drainage Characteristics

An inventory using a stream classification system is useful in describing and defining the reclaimed channel configuration (Harrelson et. al. 1994). Drainage characteristics that must be considered prior to designing the site include discharge characteristics, channel geometry, and stream morphology.

Discharge characteristics include the duration, frequency and magnitude of flow. These characteristics can change with season and climate. Consider designing drainages with a low and high flow channel or consider passing the flow across the adjacent flood plain under high flow situations.

Note: Channel designs that allow the channel to respond to a wide flow range will increase long-term stability.

Consider both bankfull flow, and extreme event flows when designing a channel to be stable. It does not matter whether the flow is ephemeral, perennial or intermittent. The channel will form according to the type and frequency of flows it receives. One must also recognize that designing for the range of flows the channel receives will result in the most stable design. Therefore, it is best to mimic the proper functioning characteristics observed in the drainage and to consider the historic flow regimes occurring at the site.



Figure 2.2: The channel was designed to allow water flow over the adjacent flood plain during high flows. Sunnyside Mine.

Streamflow types describe the duration and frequency of the flow.

- Ephemeral streams are above the water table at all times. These streams carry water only during and immediately after precipitation or during snowmelt runoff.
- Intermittent streams flow for part of the year. The water table may be elevated during part of the year. Spring discharge or the ground water flow contributes water to the stream for part of the year.
- Perennial streams flow most of the year. Definitions between perennial and intermittent streams vary. The United States Geological Survey (USGS) defined perennial sections as those stream sections which flow all year

except during severe drought periods for purpose of developing the 1:24000 series maps.

Channel-Forming Flow

There is no method to directly measure the channel-forming flow. The most common methods used to describe channel-forming flows are:

- bankfull discharge
- specific discharge recurrence interval
- effective discharge

These methods describe channel-forming flows and are determined through measured discharge and field observations collected over a representative time period. More than one method should be used to verify the channel-forming flow. To determine the channel-forming flows in cases where flow data is not available other field measurements and indirect methods such as regional analyses are necessary.

Note: When designing an ephemeral system or a system where flow data is not available, look at the existing channel form and mimic those sections that function well.

Bankfull Discharge

Bankfull flow or discharge is the discharge that fills a stable alluvial channel up to the elevation of the active flood plain. There is no standard definition of bankfull flow. Therefore, the indicators used to determine bankfull elevation (the active flood plain) must be described in the reclaimed channel design (Nixon 1959; Wolman and Leopold 1957; Woodyer 1968; Pickup and Warner 1976; Schumm 1960; and Leopold 1994).

active flood plain: *the area where alluvial materials are actively transported and deposited.*

Bankfull stage and bankfull discharge are two phrases used to describe channel-forming flows and floodplain formation. A rating curve is sometimes used to determine the bankfull elevation or stage. The rating curve plots the water elevation (feet) in the channel against the discharge (cubic feet per second). Since discharges greater than bankfull spread across the floodplain, the elevation of the water will rise slower above bankfull than below bankfull. The rating curve will flatten at the point of water spillage above the bankfull channel.

The field identification indicators used to determine the bankfull elevation are often subjective and difficult to identify and should be observed in stream reaches that are stable and alluvial (Knighton 1984).

When designing a channel through a reclaimed site make sure to re-establish the floodplain if one existed prior to mining. Not every channel will have a floodplain. An active floodplain provides temporary storage for floodwaters and sediment. A floodplain will see floodwaters an average of two out of three years. Floodplains are important to the

biological diversity and stability of the site and are essential for any riparian plants such as willows and cottonwoods.

Discharge, depth of flow, and velocity along the channel are not only important for floodplain determination, but also for determining changes of channel bed, slope, shape, or roughness. To determine the stage discharge relationship by direct discharge measurements, use velocity meters, Continuity Equation, hydraulic resistance equations (Manning's Equation) and standard backwater calculations. Review design criteria and applicable uses before applying these equations. Additionally, care must be taken with highly mobile streambeds, such as sand, to accurately represent the bed forms (roughness as described by Manning's "n") occurring during a specific event.



Figure 2.3: Willow cuttings are planted at the bankfull elevation. Sunnyside Mine.

Hydraulic Resistance Equations

Continuity Equation

$$Q = AV$$

Discharge = (cross sectional area of flow)(average velocity)

Manning's Equation

$$V = \frac{k}{n} R^{2/3} S^{1/2}$$

k= 1.486 English (1 metric)

n= Manning's roughness coefficient

R= hydraulic radius

S= surface water slope

Energy Equation

The energy equation is used to calculate changes in water surface elevations between two similar cross sections. Computer models such as HEC-2 are available for complex cross-sections and backwater situations.

Recurrence Interval

A common assumption is that the channel-forming flow has a recurrence interval of 1 to 3 years. The recurrence interval is the average number of years between when the channel-forming flow was exceeded. This method requires data analysis from a gauged station over a representative time period. Unfortunately, this data is often unavailable for stream channels undergoing reclamation. When data is unavailable adjacent gauged drainages discharge data can be applied to ungauged drainages under the following conditions:

- The watershed is hydrologically similar.
- The drainage is not dominated by high intensity storms.
- Drainages must have similar land use.

Adjacent drainage reaches should be analyzed to determine if bankfull discharge is logical. The bankfull elevation (stage) calculated from the recurrence interval method should conform to field observations. This is especially true for highly modified streams such as in urban or mined areas, as well as ephemeral streams in arid and semiarid areas.

Indirect methods for determining bankfull discharge, such as using regional analyses have been done for streams in Utah (Blakemore et. al. 1983) It is important to correctly define the active channel when using the regional analyses methods, which compare bankfull discharge with the drainage area. These methods have a wide confidence interval in the arid western portions of the state and may result in over designed or under designed streams.

Effective Discharge

Effective discharge is the increment of discharge that transports the largest fraction of the sediment load over a period of years. Effective discharge is a function of the magnitude of the event and frequency of occurrence. It represents the flow that is responsible for transporting the most sediment over a defined time period. To determine effective discharge, flow duration data and sediment load data are required (Wolman and Miller 1960).

Channel Geometry and Geomorphology

Inventory

To determine the channel geometry and geomorphology, conduct a drainage inventory prior to site disturbance. If the channel was disturbed prior to the inventory, then use the upstream, downstream, or adjacent undisturbed areas for the inventory. Inventory descriptions should be conducted by reach. A reach is that segment of the channel with similar geology, channel width, channel depth, channel slope, meander geometry, channel substrate, and vegetation. Where distinct variations in reach features occur, a reach break is made and a new description is provided. The reach descriptions are used for designing the re-constructed channel. Additional information to collect from reach inventory includes:

1. Areas where aggradation or degradation in the channel bed occur
2. Areas of significant bank erosion
3. Bed, bank and overbank roughness
4. Natural and manmade controls should be noted in the survey
5. Photo documentation for the study area.

In order for pre-disturbance inventory information to remain useful, the watershed condition and discharge characteristics during reclamation must be similar to the

conditions present during the inventory. Watershed condition and discharge characteristics respond to changes in timber and grazing activities, road construction and urban developments, climate changes and natural disasters. The response to these changes may require an additional assessment of the upstream and downstream channel characteristics prior to site reclamation. If a pre-disturbance inventory was not conducted, characteristics from a similar adjacent drainage may be preferred because the downstream and upstream channel reach characteristics may be impacted by the mining operations.

If the channel inventory demonstrates the channel is functioning properly, then the approximate channel gradient, channel sinuosity, channel form and channel bed materials should be mimicked in the reclamation design. One way to determine if the channel is functioning properly is to observe the channel during or following, the high-flow season and low-flow season. Stable sections will have efficiently redistributed sediment load and effectively transported flood flows with minimal channel adjustment or degradation. Methods to determine proper function have been developed (Prichard et. al. 1998).

Channel Substrate, Sediment, and Bedload

Sediment, bedload and channel materials are important to the channel system because they are transported when energy is available. Available power is a function of discharge and slope and it determines the sediment transport, and the adjustments the channel will make when transferring energy by moving the sediment, substrate, or bedload.

Changes to bed material and particle size distribution in the active channel and flood plain following site regrading can also affect channel stability. Regrading and handling practices can significantly change the particle size distribution within the channel corridor and flood plain. This can change the aggradation and degradation process and result in channel instability following construction.

The channel material or substrate is determined from the watershed geology and has an effect on the channel form. Generally, channels of mountain streams with durable types of rock such as granite or limestone in the upper elevations of the watershed (headwaters) will have cobble and rock in the substrate. These will be less prone to instability and will have steeper gradients with short distances between pool and riffle sequencing. Channels comprised of geologic material derived from shale, will tend more toward a "V" shape and quickly and steeply try to reach a flattened grade. Sandy substrate will trend toward wider channels with flatter gradients and meandering characteristics. Variations will occur based on other site characteristics.

Particles lifted up by eddies in the main flow are suspended sediment (Dunne and Leopold 1978). Changes in suspended sediment load have a significant effect on velocity and depth because it changes channel roughness. Suspended sediment dampens turbulence, thereby increasing the mean velocity.

The transport and adjustment of suspended sediment is important to channel reconstruction because areas where the suspended sediments are deposited along the edges of a channel are preferred sites for vegetative growth. Sediment transport can also affect the stability of riprapped channels.

The larger particles rolled or dragged along the bottom of the channel constitute bed load (Dunne and Leopold 1978). During the channel-forming processes, the gravels in a point bar or riffle section may be moved by this mechanism. It is important to be able to recognize these active areas of the channel because they will not be preferred locations for vegetation establishment.



Figure 2.4: Monkey flower established in deposited sediment in a channel reclaimed three years earlier. Gordon Creek 2, 7, & 8 Mines.

Entrenchment

Entrenchment is the vertical containment of a river and the degree to which it is incised in the valley floor. Entrenchment occurs from entrainment and transport of alluvial materials by channel erosion. Recognizing entrenchment is important for determining



Figure 2.5: Entrenched channel with no developed floodplain. Knight Mine.

whether the channel form allows for efficient streamflow transport. A deeply entrenched stream does not have access to the adjacent floodplain during a flood event.

However, systems trending toward stability will begin to develop a floodplain adjacent to the entrenched channel. Entrenched systems, trending toward stability, will require less bank reconfiguration and may be improved by adding soft bioengineering methods. Where deeply entrenched channels

trend toward instability (lack of development of an adjacent flood plain) a preferred method may be to reconfigure the adjacent flood terrace to decrease the entrenchment ratio, and an individual trained in geomorphic processes should be consulted. The entrenchment ratio describes the width of the flood prone area to the bankfull surface width of the channel. Low entrenchment ratios have depth-to-width ratios of less than 12. High entrenchment ratios have depth-to-width ratios of more than 12.

floodplain: *an area that will flood under the current hydrologic regimen and a flood terrace in this reference refers to an abandoned flood plain feature no longer actively flooded.*

Channel Patterns

Channel patterns such as pools, riffles, and meanders allow the reclaimed stream section to work efficiently and decrease the potential for failure.

The meander is the most efficient channel form that will balance transporting and depositing sediment loads with the least amount of work.

Pools are deep portions of a river sequence with bottom sediments composed of finer particle sizes in the system. Pools tend to form in meanders, beneath (at the end of or just downstream of) steep gradient drops and behind structures or natural obstacles. Pool formation is important to fishery habitat.



Figure 2.6: Pools are created using drop and rock structures and obstacles. Sunnyside Mine.

Riffles are shallow sections with increased density of larger rock sizes. Riffles are caused by deposition. A gravel bar is a type of riffle occurring alternately on one side then the other side of a channel. In straighter channels, the riffles or bars occur on alternate sides of the channel. The distance between successive gravel bars averages five to seven channel widths. Longer straight sections with finer particles are sometimes called runs.

The meander pattern refers to the curves or sinuosity of a channel. These channel bends cause an energy loss because work is required to deflect the water around a curve. Channels found in wide flat valleys have more meanders than those found in steep mountainous terrain. The average deviation from the linear down-valley direction is a function of the length along the channel. The radius of curvature for meanders of all sizes has a value of 2.3 channel widths, and the channel width and radius of curvature have a linear, or direct, relationship to the spacing or frequency of the meanders (Leopold 1994).

The thalweg is a line connecting points of maximum water depth. The maximum water depth in a fully developed meander occurs at the outer bank opposite the point bar. A thalweg is shallower at the crossover or point of inflection in curvature between two meanders.

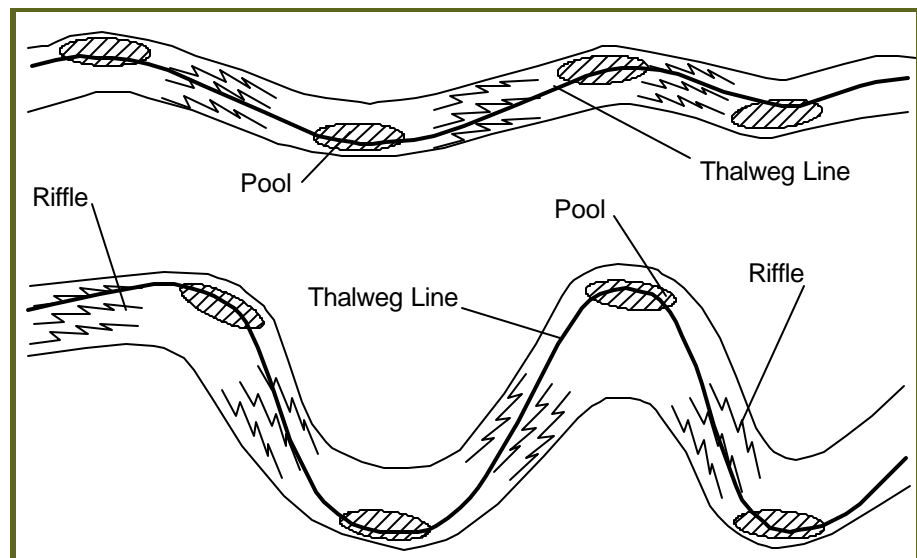

Figure 2.7: Pools, riffles, and thalwegs in meandering channels.

Braided channels are the dividing and rejoining of channels around islands. These are not common at most reclamation sites and are more common in large rivers. However, if the bed load is significant, the potential for braiding needs to be considered.

Drainage Reclamation Considerations

Regulatory Requirements

Reclamation in and around stream channels will require regulatory approval for the action prior to initiating the project. Contact the agency to permit or approve the activity to determine the specific requirements related to the action.

Table 2.1: Possible Stream Channel Regulatory Requirements.

Action	Requirement	Agency
Disturbance - most construction activities	State: Non-point Source Pollution Management Program	Department of Environmental Quality, Division of Water Quality (DWQ)
Water diverted or used in construction not associated with acquisition from a municipal source.	State Water Right	Department of Natural Resources, Division of Water Rights
Stream alteration	General Permit 40 Corps of Engineers/Dredge and fill operations Section 404.	State Engineer/Division of Water Rights
Disturbing wetlands	Dredge and fill operations Section 404.	Corps of Engineers

Reclamation

The details and design for stream channel reclamation should be developed from the discharge characteristics, channel geometry and geomorphology obtained from the channel inventory. Develop drainages and landform designs that promote overland flow.

It is important that materials placed in the channel receive special handling. Place bedding materials within an area that provides adequate depth and breadth to account for possible channel adjustments. The channel bed material size and gradation should be appropriate for the channel slope and configuration. Other practices conducted to preserve the substrate may include:

- Minimized disturbance within the channel and flood plain.
- Importing fill with the proper gradation and characteristics similar to the pre-existing materials.

Failure to define tributaries can lead to erosion in an upstream direction (head cutting or nick points) in the reclaimed channel and adjacent areas. Tributaries may also be a source of additional sediment loading that can result in island formation or channel

braiding. A potential to increase erosion, gully and nick point formation can result from inappropriate landform and backfill materials. Replacing the drainage network to levels observed in premining conditions will decrease the potential for erosion assuming there are no major changes in soil texture in the surrounding reclaimed landscape. Creating landforms, such as slope breaks and small subdrainage areas, will reduce erosion maintenance costs, as will promoting overland flow in landform and drainage designs.



Figure 2.8: Divirting and concentrating water flows can lead to costly repairs. Hidden Valley Mine.

Reclamation Specific to Discharge Characteristics

The reclamation of ephemeral drainages is determined by flow characteristics related to watershed area, topography, gradient, slope, substrate, and sediment load. In systems where the drainage is in the upper watershed with small drainage areas feeding the channel and good vegetation establishment potential, a standard riprap channel or buried channel can be used.

For ephemeral systems where the drainage contains excessive sand or bedload movement during runoff events, the channel design needs to consider these conditions. The channel design may need to incorporate a zone where channel adjustments will not jeopardize an adjacent steep slope, retained road, or other buried or retained structure. However, surrounding and pre-existing site conditions will dictate whether these concepts should be implemented.

In extremely sandy and silty soils where the system responds to high flow events and heavy sediment loads, grade control structures and flat wide channels may be preferred to riprap designs.

Riparian vegetation and soft bioengineering structures are important to the function and design of intermittent channels. They generally have adequate moisture available so that vegetation can provide additional stability and roughness to the flood plain and can increase channel stability. Channel form, including meander ratio, should be considered. Analysis of the potential effects from man made structures upstream and downstream from a reconstructed section including any culverts or bridges retained for the post mining land use need to be considered. Intermittent streams may provide aquatic habitat important to downstream fisheries, which may affect design criteria such as gravel substrate, and vegetation types, which in turn can affect stream temperature.

Channel form, pool/riffle ratio and meander geometry become very important for perennial streams. As with intermittent streams, vegetation and channel form can add to channel stability. Soft bioengineering methods are desirable. Substrate appropriate for the slope, channel form, as well as use of the bankfull width and adjacent flood plain in the

channel design become important. The presence of fisheries may dictate special habitat forming designs.

Other Situations

Confluence of Two Channels

When designing the confluence of two channels (including tributaries) considered the following factors:

1. The potential for the confluence to become an area of deposition
2. The directions of flow at the confluence of the merging channels

If one channel carries considerable sediment and bed load then the confluence could become an area of deposition. This requires a design where channel widening and adjustments can occur or the gradient should be increased to effectively transport the added sediment load. Design the confluence so the flow enters the channel in the same flow direction and is compatible with channel form and geometry at the site.

Construct the appropriate grading and landform at the junction. In general, when two channels join, the combined width is the sum of the squares of the joining widths. Width increases as the square root of a discharge with constant frequency (Leopold 1994). Although width is considered most important when designing for perennial streams, converging downstream channel width can vary in both intermittent and perennial systems.

Adjacent Concentrated Flows

Success in developing the main channel is often determined by adequately identifying adjacent areas where concentrated flows will form and contribute to the main channel. These areas can develop rills and gullies, nickpoints and headcuts. Extra considerations include existing low profile drainages, rock outcrop areas, and impervious drainage areas that contribute flow over the reclaimed area.



Figure 2.9: A defined ledge was excavated to allow adjacent concentrated flow to enter the drainage area in a controlled manner. Caste Gate Mine.

Depending on the drainage area and proposed regrading characteristics, a number of methods may be implemented to control flow from adjacent areas. Drop pools may work where there is a defined ledge and competent substrate below the pool. Developed scree slopes can be useful where drainage from steep small drainage areas transition to a lower gradient reclaimed section. Landform using swales that will transport the water to the stream may be adequate. In longitudinal cross-section, each of these landforms should be concave where the gradient changes from steep to flatter ([Part 2, Section 5](#)).

Connecting the Reclaimed Channel Into an Existing Channel

Give extra attention to areas where the initiation or completion of a re-constructed channel is tied into an existing channel. To minimize failure at the upstream and downstream locations, designs that tie into the existing channel are important. If a significant grade change occurs at the tie-in, deposition, or scour can result, which destabilizes the channel downstream, upstream or, at the point of tie-in. Where riprap is used for channel reconstruction an additional keyway with a depth and width that extends beyond the excavated channel can provide additional protection from failure in some situations.

keyway: a trench filled with rocks.

Methods To Obtain Stability

Riprap

Uses

Riprap is best used in intermittent and perennial streams, and in some ephemeral streams. The effectiveness of riprap will be reduced in systems receiving short duration, highly turbulent flows if the reclaimed channel contains a highly mobile, sandy or non-colloidal substrate. The high sediment and velocity can increase mobility of larger rock in the bedload, thereby dislodging riprap.

Construction



Figure 2.10: Riprap is rock with a specific mixture of sizes or gradation, used to stabilize drainages. Boyer Mine.

Channel Excavation and Grading

After the grade for a channel is determined, the most important part of the construction is adequately excavating below the proposed channel elevation in order to install the riprap and gravel filter blanket.

Following riprap installation, conduct the remaining site grading to insure overland flow reaches the channel and flow does not parallel the channel, which can cause down-cutting and channel failure. The elevation of the earthwork immediately adjacent to the channel should be above the uppermost edge of riprap placement

Riprap Materials

Be sure riprap is dense, sound, resistant to abrasion, and free from cracks or other defects that make it susceptible to weathering. Rock should be angular to subangular quarry stone. Make sure the width or thickness of a stone is more than 1/3 its length. Do

not use rounded river rocks. Unit weight should be greater than 155 lbs/cubic feet. Rock must not be soluble and disintegrate when in contact with water.

Riprap Design Methods

Rock should be well graded and sized based on channel-forming flows. Procedures using Simons and Senturk (1977) produce riprap sizes for flow on a plain sloping bed. The safety factor for this method must be greater than one. However, a safety factor of 1.5 is recommended. The thickness of the riprap should be at least the thickness of the largest diameter stone.

The method provided by Simons and Senturk (1977) for a plain sloping bed only applies to channel bottoms. The riprap sizing on channel banks and channel bends must also be determined. These methods are tested for flat slopes and become unusable as slopes get steeper. Unfortunately, steeper slopes result in oversized riprap, which can result in an inability to obtain proper gradation and make installation unreasonable.

Numerous methods describe riprap design on a plane sloping bed (Searcy 1967; Haan et. al. 1994; Searcy 1967; Norman 1975; SCS 1979; Simons and Senturk 1977).

Filter Blanket



Figure 2.11: A cloth filter blanket liner is exposed after flows in this ephemeral channel. Knight Mine.

A gravel filter 'blanket' should be designed for each riprapped channel. The gravel filter blanket should contain clean gravel composed of hard, durable stone and be free of fine sand, silt or clay (D_{min} -200 mesh). Filter bed gradation sizing is based on the riprap size and the base material. Filter thickness should be $\frac{1}{2}$ the thickness of the riprap (D_{max}), but not less than 6 to 9 inches. The filter bed should be compacted following placement.

In general, do not use cloth liners for the filter blanket. When cloth liners are used the riprap is easily de-stabilized.

Note: If the riprap is loosened, the liners will tear and erosion will occur underneath the liner. This can further de-stabilize the channel, exposing the cloth to additional erosion and failure.

Potential Problems

Success of any riprap-lined channel depends on factors other than simply sizing the rock required. Of particular importance to a successful riprap-lined channel is the gradation and placement of the riprap. These two criteria may determine the success or failure of a channel (Simon and Li 1982).

Problems with riprap occur when angular riprap and adequate gradation are not used. Lack of proper gradation is one of the most common causes of riprap failure. Gradation implies a distributed size range of rock. With distributed size range, the interstices formed by the larger stones are filled with the smaller sizes in an interlocking fashion that prevents formation of open pockets. Open pockets allow jets of water to contact the underlying soil, resulting ultimately in failure. The lack of proper gradation allows water to flow around and through the rock and can make the rock buoyant and move it downstream. Likewise if the rock is not angular it will not interlock with the adjacent rock and will be more easily transported.

Do not place riprap on areas where competent exposed bedrock is present. Where riprap is placed on bedrock the riprap can be easily moved downstream. Once rocks are mobilized, downstream riprap also become destabilized.

Buried Channel

Uses



Figure 2.12: Construction of a buried channel begins with a well-constructed riprapped channel. Boyer Mine.

Best used in ephemeral channels with the potential for vegetation establishment and where there is not a considerable contribution of sediment from the high, flashy flows produced offsite. The effectiveness of a buried channel will be reduced if the reclaimed channel contains a highly mobile, sandy or non-colloidal substrate.

Construction

Construction begins with a well constructed riprapped channel that is then covered in topsoil and vegetated. Two concepts are important to success of the buried channel.

1. The channel is over designed on purpose to withstand the high-intensity, short duration flows that occur in the region while the earthen material allows low flow channel development and vegetative establishment.
2. The finer particles are available for transport so the channel can continue to move sediment without increasing velocity and stream competence (ability to transport material). Increased stream competence could result in channel failure.

Potential Problems

The same potentials for failure can occur as in riprapped channels, but the finer particles may reduce stream competence and fill smaller voids in the riprap, thus increasing stability.

Log Weirs/ Rock Weirs

Uses

Log and rock weirs are typically used on perennial and intermittent streams and are often used to increase habitat diversity for fisheries. The weirs are also used to provide sediment traps and raise the stream bed elevation.

The vortex rock weir is a grade control structure. These structures have been refined by David Rosgen and others, to provide grade control without backwater conditions. They also provide habitat enhancement in perennial/intermittent streams. Although, vortex rock weirs are not presently widely used in Utah's mining reclamation sites, they have great potential because they do not create backwater conditions, which cause channel widening and subsequent cutting around the structure. Widening and cutting is observed when using the standard log and rock weirs that cross the stream perpendicular to the flow.

Construction Rock of Weirs

The Vortex Rock Weir is constructed with an upstream pointing "V". The construction of the "V" should direct the flow toward the thalweg in the stream section. The thalweg is the line connecting the points of maximum water depth in a general downstream direction along the channel. Footer rocks are set under the weir (elevated) rocks at channel bed elevation. The weir rocks are laid on top of the footer rocks. Place the structures every two to three channel widths and at points of curvature in and out of meander bends. Set tops of vortex rock at a maximum 20% of bankfull depth, defined as the bankfull flow that is most responsible for forming or removing bars, forming or changing bends and meanders, and resulting in the average morphologic characteristics of channels (Dunne and Leopold 1978).

Potential Problems

Potential problems with rock and log weirs can occur when the weirs are not constructed to convey the flows in the proper direction. Improper placement of the weir can force water into a downstream bank and cause erosion and stream de-stabilization. If the weir does not have a low width to depth ratio or, is not adequately anchored into the bank and the low point in the weir is not in the thalweg (main flow path), the structure can cause the channel to widen and cut around the structure.

The vortex weir design has had problems with unacceptable aggradation (deposition of transported bedload) around the rock. Designs indicate the distance from the center of the channel from the wide end of the "V" to the upstream point needs to be 2.5 to 3 times the average intermediate diameter of the boulder used.

Streambank Bioengineering

This section is primarily a summary of material found in The Practical Streambank Bioengineering Guide, (Bentrup and Hoag 1998), an excellent resource for bioengineering projects in the intermountain west. To receive a copy, go online to <http://www.nhq.nrcs.usda.gov/BCS/PMC/pubs/IDPMCpubs-sbg.html> or mail a request to the USDA-NRCS Plant Materials Center, PO Box 296, Aberdeen, ID 83210.

Bioengineering increases the strength and structure of soil by integrating living, woody and herbaceous materials with organic and inorganic materials. Bioengineering includes a wide array of techniques and is often used to protect streambanks and shorelines from erosion damage. Above-ground plant parts slow water velocities and dissipate energy, while the root-mass holds soil together.

Bioengineering techniques are the biological equivalent of traditional streambank stabilization methods such as riprap, concrete revetments, and concrete-lined channels. Consequently, direct comparisons can be made between the two approaches. The following lists identify some of the major advantages and disadvantages associated with bioengineering techniques.

Disadvantages

- **Possible plant growth failure**-This may be due to scouring; livestock and wildlife grazing, and uprooting by freeze/thaw action, ice flows, and debris loads.
- **Periodic maintenance**-The project may require periodic maintenance, especially early in the project life.

Advantages

- **Cost effectiveness**-Traditional hard structures require more maintenance over time and are much more expensive to repair in the event of failure. However, bioengineering projects are usually maintenance-free after the project matures.
- **Visual effects**-Bioengineering techniques visually blend into the landscape.
- **Wildlife**-Bioengineering provides fish and wildlife habitat and often improves water quality.
- **Natural changes**-An important advantage of bioengineering over hard-engineered methods is the ability to evolve with the stream and respond to changes naturally.
- **Environmental compatibility**-Indigenous, natural materials such as earth, vegetation, rock, and lumber are used in place of concrete and steel.
- **Labor-skill requirements**-Bioengineering projects rely more on easily trained labor than on high-cost manufactured materials, making the use of volunteer labor feasible.

To complete a bioengineering project, you must:

1. Analyze the watershed and determine the large-scale reasons for degradation. It is important to note other potential non-mining contributors to stream degradation because they may affect the particular strategy or bioengineering techniques used.
2. Work with the landowners within the watershed to modify poor land management practices as necessary.
3. Enlist technical expertise and begin initial inventory of areas that may benefit from bioengineering. Begin to develop site-specific objectives. Landscape architects, plant ecologists, hydrologists, soil scientists, and NRCS field office personnel are frequently helpful.
4. Inventory and analyze prospective sites and determine causes of bank failure. Select a project site and refine objectives.
5. Design a site-specific bioengineering project to meet the objectives.
6. Gather input and permits as necessary from regulatory agencies, such as the Division of Water Resources and the Division of Wildlife Resources.
7. Implement the project. It is usually best to start at the furthest upstream reach and work down if all work cannot be completed in one year.
8. Monitor and maintain the project. Evaluate for future projects.

Stream Channel Design Guidelines

Before proceeding with a bioengineering project, analyze the natural characteristics and land use patterns of the entire watershed.

The hydrology of a stream will determine whether plants have enough water available to survive through the growing season. It also determines the strength of the erosive forces and plays an important role in determining the streambed characteristics. This section contains a brief introduction to some of the important variables of stream hydrology and the equations used to calculate them.

Velocity

Velocity is a major component of erosivity. On simple streambank stabilization projects, the velocity can be measured directly. When the channel is being redesigned, velocity can be calculated with Manning's equation, where R varies with the dimensions and shape of the channel, and n values are available in various publications.

$$V = \frac{(1.49 * R^{.667} * S^{.5})}{n}$$

Where

V = velocity (ft/sec)

R = hydraulic radius (x-sectional area/wetted perimeter in ft²/ft)

S = slope (ft/ft)

n = coefficient of roughness

Magnitude of Discharge

If the velocity and cross-sectional area of the stream can be measured or calculated, it is easy to calculate the magnitude of discharge.

$$Q = V * A$$

Where

Q = discharge (ft³/sec)

V = velocity (ft/sec)

A = cross-sectional area (ft²)

Tractive Forces

This is one of the most important hydraulic design criteria for bioengineering projects. It is a measure of the shear stress, or erosive force, being exerted on the banks and bed of the stream and will determine the amount of protection needed.

$$T = \gamma d S$$

Where

T = tractive force

γ = unit weight of water (62.4 lb/ft³)

d = depth of flow for a particular discharge event (ft)

S = slope (ft/ft)

Table 2.2: Maximum Tractive Forces for Bioengineering.

Technique	Lbs/ft ² immediately after completion	Lbs/ft ² after 3-4 seasons
Herbaceous reed plantings	10	70
Deciduous tree plantings	50	290
Willow wattle	145	190
Brush layer	50	340
Brush mattress	120	725
Riprap with live cuttings	480	725

Planting Design Guidelines

Species Selection and Placement

Observe the existing types of plants and their respective locations in relationship to the stream and water table (Figure 2.13). Try to recreate this structure in the design. Plants with flexible stems and rhizomatous root systems are usually located from the water line to mid-bank zone. Larger shrubs are found from mid-bank to the top of the overbank zone. Tree species are usually found above the overbank zone in the floodplain. Wetland herbaceous species can be found throughout the streambank cross-section, although most emergent aquatics will be found in the toe zone.

Successful bioengineering projects depend on proper selection of species, plant material procurement and handling, planting location, and establishment techniques. Knowledge of riparian plant species is essential. Only certain species of plants grow naturally in riparian environments. Of those species, some are more useful than others for bioengineering and bank stabilization. Woody vegetation that is adapted to moist or saturated conditions, able to sprout from cuttings, and has deep, spreading root systems is ideal. Willows are a classic example of a shrub meeting these criteria.

Trees, such as

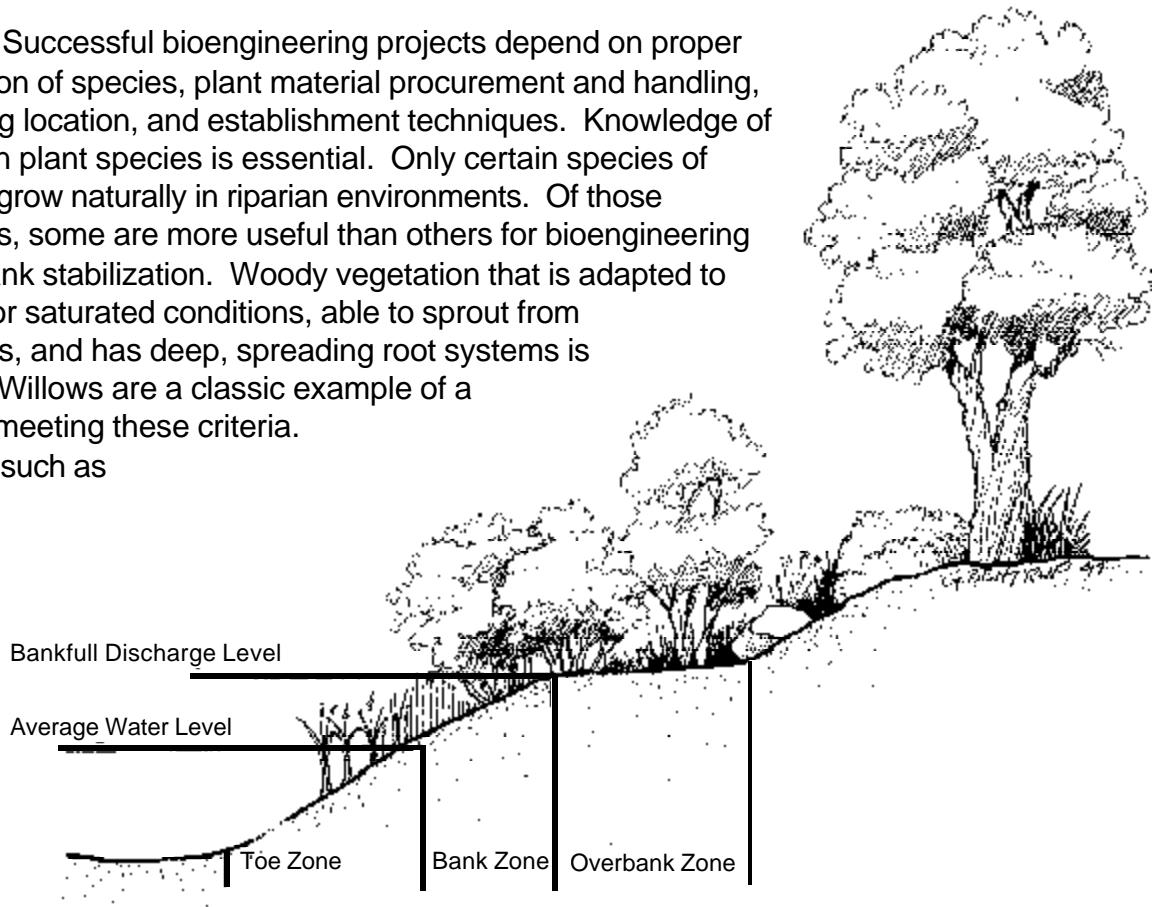

Figure 2.13: Certain plant types and species occupy different zones on the bank of a stream. (Graphic reproduced from Bentrup and Hoag, 1998.)

cottonwood, may be appropriate in some areas, but need to be planted out of the bankfull discharge area because they will not survive frequent high flows. Herbaceous plant materials are also an essential components of most bioengineering projects. Ultimately, proper species selection should be based on what is observed in the surrounding natural conditions.

Plant Procurement and Handling

Woody plant materials for bioengineering are typically bare-root stock or dormant, unrooted hardwood cuttings. The main benefits of using hardwood cuttings are lower cost, ease of planting, depth of planting, use of local ecotypes, and availability. The following is a list of information and guidelines for using hardwood cuttings:

- **Types**-Cuttings can be used as poles (1/2 to 3 inches in diameter, planted singly), posts (3 to 6 inches in diameter, planted singly), or bundles (small diameter cuttings used in wattles, brush layering, and other techniques).
- **Timing**-Cuttings should be collected during the dormant season, from leaf fall to just before the buds begin to break in spring. Just after spring run-off is usually the best planting time. The cuttings will have adequate moisture but will not be subjected to high flows.
- **Harvesting**-Collect cuttings from live wood that is at least two years old but not old and furrowed. Use sharp equipment capable of making clean cuts. Do not take more than 2/3 of the stems in any one plant if the plant is to remain in place and continue to grow. Cutting length varies with the application, but must be long enough to extend 6-8" into the permanent water table or capillary fringe. Two-thirds of the cutting should be below ground level.
- **Handling**-Trim off all side branches and the terminal bud so energy will be rerouted to the lateral buds for growth. Cuttings can be tied into bundles for transporting and soaking. Then, the cuttings can be stored for up to six months in a cool (34-36 degrees F), humid, dark place until ready to plant. Prior to planting, soak the cuttings in water for five to seven days to prepare for rooting. Plant immediately after removal from the water.
- **Other Plant Sources**-Potted plants, transplanted plugs, rhizomes, clump plantings, and seeds can all be used.

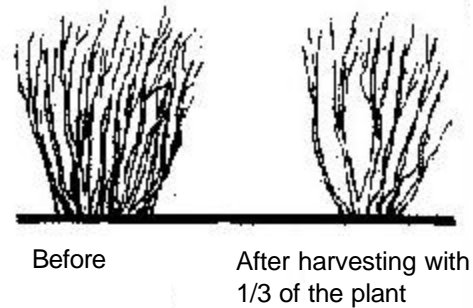

Figure 2.14 : Never harvest more than 2/3 of the stems of one plant. (Graphic reproduced from Bentrup and Hoag.)

Implementation of Design

Establishment Techniques

Pole plantings are normally planted with planting bars, soil augers, or power augers. Post plantings are planted with post-hole diggers, tractor mounted posthole augers, and a backhoe-mounted bar called "The Stinger." Bundled cuttings are planted according to the specific technique. Whatever the planting method, consider the following general establishment factors:

- Cuttings must reach the permanent water table or capillary fringe.
- Minimize major damage to the buds when inserting a cutting in the hole. Avoid separating the bark from the cambium layer.

- Make sure there are no air pockets around the cutting. Backfill with a soil and water slurry to remove air pockets.
- Experiment with planting methods to determine a suitable method for your site conditions.
- Fertilizers and rooting hormone rarely improve success of high volume plantings enough to offset the cost and the extra labor involved.

Management

Land management practices in the surrounding area have a large impact on the success of bioengineering projects. If a management change is needed and the owner refuses to make the change, the chances for a successful project are low.

Livestock, beaver, muskrats, ducks, geese, deer, elk, and other wildlife can be devastating to new plantings. Generally, livestock should be fenced out of the area for two to four years. Excluding wildlife can be much more difficult. Potential problem species should be identified early in the planning stages. Control methods for wildlife vary, but include fencing, plant cages, repellents, and trapping.

Bioengineering projects will require some initial maintenance. Typical maintenance tasks include:

- Clearing debris around plantings
- Securing stakes, wire, and twine
- Controlling weeds
- Repairing fences
- Replanting

Some replanting is usually necessary to ensure the streambank is fully vegetated in a short time frame. The need to replant should not be looked at as a failure. The following table illustrates some potential success rates for bioengineering practices.

Table 2.3: Potential Success Rates.

Method	Growing
Pole Plantings	70-100%
Live Fascines	20-50%
Brush Layering	40-70%
Post Plantings	50-70%

An important component of a successful bioengineering effort is a good monitoring program. Revisit the project periodically and carefully note its progress. Monitoring efforts will not only increase the success rate of the current project, but will also provide valuable insight to be used in future projects.

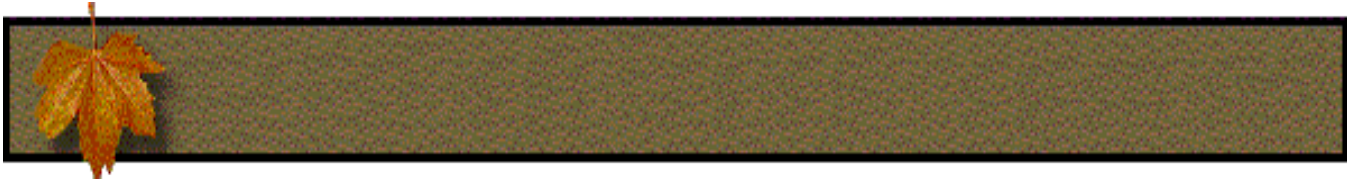

Chapter

3

Handling Soils

- **Soil Salvage**
- **Soil Placement**
- **Problem Soils**
- **Erosion**

Soil Salvage

Soil is the unconsolidated cover of the earth. Soil is made up of mineral and organic components that are capable of supporting plant growth. Topsoil is generally the most fertile portion of soil that contains the nutrients, microorganisms, seeds, and roots for enhancing reclamation. Salvage and replacement of topsoil promotes vegetation establishment and is required by law to ensure reclamation success.

Topsoil salvage, stockpiling, and replacement activities require large equipment and a large amount of time. Planning and coordination ensure that soils are salvaged ahead of operations and that replacement and seeding operations occur in a timely manner.

Planning Soil Salvage

Experience with reclamation at a variety of mined sites has proven that replacing 12 inches of topsoil on the surface after grading will substantially improve plant growth. Because roots will extend into the graded overburden, it is also important to prepare the overburden to a depth of at least 1 foot. In other words, the preferred rooting depth is two feet with the top 12 inches being topsoil.

Note: More cover may be necessary if toxic material is to be buried.



Figure 3.1: Rock blending on the surface of the reclaimed site. Willow Creek Mine site.

In searching for 12 inches of topsoil from the site, the mine operator should not discard rocky or bouldery soils. The objective of reclamation is to mimic the surroundings and blend the restored site with undisturbed area. In some cases, this means salvaging rock and boulders with the soil cover.

To determine if the operation can supply twelve inches of topsoil, the operator should take the following steps:

- Review the County Soil Survey, which is available at the local National Resource Conservation Service (NRCS) office:
<http://www.ut.nrcs.usda.gov>
- Look for a description of the soils and vegetation likely to be found within the proposed disturbed area.
- Evaluate the texture of each soil (percentage of sand, silt, and clay), the water holding capacity, the pH, and the salinity or electrical conductivity (EC), as well as the average rooting depth to determine the potential for salvageable soil over the disturbed area (Table 3.1).
- Determine the depth of salvage. If suitable material is not found at the surface, look for subsurface materials that fit the criteria in the Soil Evaluation Table.

Conduct an inspection of soils at the site prior to disturbance. The inspection will help to correlate the site soils with those described in the County Soil Survey. Record all vegetation, salt crusts, shale, rock outcrops, steep slopes, and other hindrances to soil salvage. Where problem areas exist, such as those with salt and shale, take samples for laboratory analysis of pH, EC, and sodium adsorption ratio (SAR). See Table 1. After an inspection of the site, the NRCS may aid in determining the extent of the problem or in recommending amendments to the soil for reclamation.



Figure 3.2: Soil sampling in Hardscrabble. Canyon Castle Gate Mine.

Before mine operations begin, remove and store all the available topsoil material and attempt to achieve the twelve inch topsoil goal.



Figure 3.3: A soil pit is dug to evaluate soil quality and quantity.

Even a few inches of topsoil will make a difference in plant establishment at reclamation. Where topsoil is limited, ensure that the graded surface is suitable for plant growth.

Table 3.1 Soils suitability table*

	Good	Fair	Difficult	Expect Problems
pH	6.1 to 8.2	5.1 to 6.1 8.2 to 8.4	4.5 to 5.0 8.5 to 9.0	less than 4.5 >9.0
EC (mmhos/cm)	0 to 4	4 to 8	8 to 15	>15
SAR	0 to 4	5 to 10	10 to 12	>12
texture**	sl, l, sil, scl, vfsl, fsl	c, sicl, sc, ls, lfs	sic, s, sc, c, cos, fs, vfs	g, vcOS
avail water holding	>0.10 moderate	0.05 to 0.10 low	<0.05 (very low)	

*Soil suitability rating may vary based on the pre-existing plant community and soil types and desired postmining plant community.

**s=sand, l= loam, si= silt, c= clay, v= very, f= fine, co=coarse, g=gravel

Most operations will benefit from conducting a detailed soil survey. The objective of a soil survey is to document the kind, extent, depth, location, and quality of soils in the survey area. A survey will describe the topography, elevation, and rainfall characteristics of the site, as well as the plant community and its productivity. The survey will provide background information that will be used in formulating the soils management plan for operations and reclamation (Table 3.2). The information obtained during the survey is used to create a soils map of the site on a scale of 1:15,000 or larger.



Figure 3.4: A greasewood plant community thrives in soils with high EC. Carbon County.

A soil survey follows the methods, standards and procedures described in Title 430-VI of the National Soils Handbook, (USDA-NRCS 1993), Soil Survey Manual (USDA-NRCS 1993), and Keys to Soil Taxonomy, 7th ed. (USDA-NRCS 1998). The Division recommends that a certified soil scientist conduct this investigation. Certified individuals are listed by state, specialty, or name at <http://www.agronomy.org/certification/directory>.



Figure 3.5: Soil profile from borrow area. Star Point Mine.

The survey contains information collected from soil pits and supplemental auger holes arranged on transects throughout the site. The pits provide soil scientists the information on soil horizons and the opportunity to collect soil samples. The samples from each horizon or from each 12-inch increment (where no horization is noted) are analyzed for pH, electrical conductivity (EC), texture, percent organic matter (%OM), available water holding capacity, calcium carbonate (CaCO₃), soluble potassium, magnesium, calcium, and sodium, total nitrogen, and available phosphorus. From this information, the SAR is calculated (USDA 1954). The results of this sampling will be used to evaluate soil types that are less desirable for salvage and reclamation. For example, a good soil will have SAR values below 5.0 (Table 3.1).

Note: With the results of the survey, the following balance sheet can be used to track the volumes of material available for use at reclamation.

Table 3.2 Topsoil balance sheet.

	Area 1	Area 2	Area 3	Total
Acres (ac)				
Depth of Topsoil Removal (ft)				
Estimate of Salvageable Topsoil $\frac{(ac \times ft)}{27} = CY$				
Volume Actually Salvaged (CY)				
Storage Location and Capacity (CY)				
Depth of Proposed Topsoil Replacement				
Volume Required for Reclamation (CY)				
Surplus or Deficit Volume (CY)				

Note: When filling out the Topsoil Balance Sheet, the following equivalencies may be useful:

27 Cubic Feet (CF) = 1 Cubic Yard (CY)

1 Acre = 43,560 Sq Ft

Topsoil Salvage, Storage and Preservation

A suitable plant-growth medium is essential for land rehabilitation. Because soils develop very slowly in the arid West, topsoil is a valuable resource. Topsoil is valued as the most superior plant-growth medium and therefore, should be selectively handled and preserved for use during reclamation.



Figure 3.6: Arid land with 8-12" annual precipitation is the site of many Utah mines.

Topsoil Removal

Remove topsoil and substitute topsoil resources prior to any other mining activity. Soil resources can either be stockpiled for later application or removed from the active mining area and immediately spread over graded overburden. The latter option, which is called live haul, is preferable because fresh topsoil contains microbes/bacteria, viable seeds, and plants that take root and aid in stabilizing the site. However, in many cases, topsoil stockpiling is the only choice for preserving soil resources.

Plan in advance to minimize the area of disturbance and reduce soil handling. When planning, be sure to:

- Give forethought to vehicle access to the soils.
- Provide on-site supervision during the soil salvage operation for soil identification and stripping control.
- Use dust control measures during topsoil stripping activities and stop activity if dust is inadequately controlled.



Figure 3.7: Soil pedestal remains after topsoil salvage. West Ridge Mine.

To remove soil in a controlled manner, the following methods are employed:

- Leave pedestals, which are small islands of topsoil to verify soil removal depth.
- Dig pits or trenches with a backhoe to confirm the depth of topsoil to remove.
- Have a qualified soil scientist on-site to supervise the topsoil salvage operations.
- Use a contractor with previous experience in soil salvage operations.

Once stockpiled, do not disturb the soil again until final reclamation. The stored topsoil should:

- Remain in place for the duration of mining
- Not be subject to water or wind blown contaminants
- Not be subject to compaction

Note: Place signs on the stockpile to help avoid accidental disturbance.

In Utah, segregation of topsoil from the underlying subsoils often means salvaging both the A and B horizons, since the A horizon is so shallow. Where possible, separately stockpile the B horizons from the overlying A horizons. At reclamation, replace the A and B horizons in the reverse order of stripping so that the native soil profile is duplicated. This effort will result in higher productivity of the reclaimed site.

Prime farmland soils require special handling. The topsoil is segregated from the subsoil, which is salvaged to a depth of four feet. The soil is replaced in the reverse order of stripping to restore its former farmland productivity.

Cryptobiotic Crust

Soils with cryptobiotic crusts also require special handling. Cryptobiotic crusts are a living, complex association of cyanobacteria, lichens, mosses, and green algae. These crusts are very important in arid and semi-arid plant communities for providing soil stability, increasing water infiltration, and creating soil aggregation (Belnap, unpublished). Separately salvage the top inch of dry crust material from the soil before salvaging the topsoil. Spread the crusts as thinly as possible over the topsoil storage piles to keep them active.



Figure 3.8: Cryptogams on undisturbed soil. Emery County.

Preserving Soil Structure, Avoiding Soil Compaction

"Soil structure" is used by soil scientists to describe the soil's aggregate stability, or primary particle arrangement and the resulting pore system. This is an important concept because the pore network in the soil holds water and dissolved nutrients and allows air infiltration and root penetration into the soil. Even good quality soil is subject to compaction, which results in loss of the pore network and is measured by higher soil bulk density. The results are increased soil compaction and higher soil bulk density. During soil salvage and soil replacement, preserving soil structure and avoiding soil compaction is of paramount importance.

Soil structure is impacted by several factors, including:

- Handling. Minimize the number times the soil is moved.
- Compaction. Minimize the amount of vehicle traffic.
- Moisture. Avoid handling soils when they are either too dry or too wet.

Handling soil that is too wet or too dry with earthmoving equipment will result in the soil becoming compacted or turning to powder. Both conditions seriously affect plant growth. To illustrate how soil consistency varies with water content, try moistening a hard, dry clod. Notice how it softens as water penetrates into the soil structure. At low water contents, the soil becomes friable and crumbles under gentle pressure. Increasing water content allows the soil to become plastic and it can be molded without cracking or crumbling. Further wetting will cause plasticity to give way to stickiness, a consistency to be avoided during soil salvage or replacement.

Soils should only be handled when they are in a loose or friable condition or when moisture content is an optimal 10%-15%. Loose consistency refers to non-coherent, coarse-textured soils while friable consistency refers to fine-textured soils that crumble readily when crushed.



Figure 3.9: Dry soil turns to powder after handling. Banning Loadout.

Generally, two rules apply:

1. If the soil sticks to the equipment, wait until the soil has dried to a friable state.
2. If the soil is too dry and hard to handle, resembling flour, add water until the soil is wetted to a loose, friable condition.

There are natural processes that alleviate compaction and restore soil structure after salvage and placement.

They include:

- Wetting and drying
- Freezing and thawing
- Root penetration
- Organic matter decomposition



Figure 3.10: Topsoil pile with organic matter. West Ridge Mine.

Incorporate organic matter into the topsoil piles by salvaging plant materials on the surface with the topsoil. Such plant materials include grasses, shrubs, and chipped woody materials.

Note: Additional nitrogen may be required.

Soil Storage

Store salvaged soil in a manner that:

- Minimizes southwest sun exposure
- Maximizes surface area
- Minimizes soil depth

In addition, the stockpile should be:

- Isolated to minimize contamination from mine related dusts
- Protected from flooding
- Seeded promptly, since plants and their residue control wind and water erosion and maintain microbial activity.

Short-term piles should be:

- Seeded with a mix of quickly established grasses and grains that can be tilled under as a green manure soil amendment
- Seeded with an interim seed mix of grasses, forbs and shrubs, if the pile is to remain in place longer than one year

Note: Maintenance of topsoil piles includes weed control.



Figure 3.12: Soil is stockpiled for use in reclamation. West Ridge Mine.

Rock Fragments

Islands of vegetation diversity are desirable, particularly in large disturbance areas of more than 30 acres. Salvaging soils that are rocky or bouldery allows the site to blend with the surrounding, undisturbed areas. Rock increases soil water absorption, reduces evaporation, alters soil temperature, provides habitat, promotes plant diversity, and helps reduce surface soil erosion.



Figure 3.11: Topsoil pile construction. West Ridge Mine.

Keep in mind that soil changes during storage. Chemically, the pile loses organic matter and fertility. Biologically, the numbers of microbes decrease with time and depth of burial. Earthworms decrease and viable seeds are eliminated. Physically, soil aggregate stability is lost. The soil becomes compacted with a high bulk density.

To minimize compaction caused by earthmoving equipment, use single lift operations rather than repeatedly driving over the surface scraping off thin layers. Also, wide, shallow soil stockpiles will retain more microbes, earthworms, and viable seeds.

Livehaul of salvaged soil eliminates the problems of stockpiling. Live haul is the direct placement of freshly salvaged (not stockpiled) topsoil onto graded overburden in another area of operation. Consequently, deterioration of fertility, micro-flora, and seed viability are avoided.



Figure 3.13: Dumptruck carrying topsoil to a remote storage location. Hiawatha Mine.

Substitute Topsoil Salvage

Substitute topsoil is sometimes necessary to achieve reclamation success. Use substitute topsoil where soils are extremely thin, have been contaminated, or where toxic mine and rock waste require deep cover to provide a plant rooting zone.

Substitute topsoil is created from mixtures of subsoil, geologic strata, and mine spoils. Substitute topsoil should have physical and chemical properties similar to, or better than, the native soil materials for supporting vegetation and the post-mining land use. The criteria used to evaluate the suitability of topsoil substitutes are listed in [Table 3.1](#).

Note: The morphological, physical, chemical, and mineralogical properties of substitute topsoil materials may change rapidly when they are exposed to surface conditions and weathering. For example, oxidation of shale will produce clay, while oxidation of pyrite produces acidity.

Prior planning and onsite supervision of salvage operations will assure the identification and surface placement of useful substitute topsoil materials during backfilling and grading, leaving the less desirable materials buried in the fill.

Preserving Topsoil In-Place

In 2000, the West Ridge coal mining operation, in cooperation with the Utah Coal Regulatory Program, investigated an alternative method for preserving topsoil resources on steep slopes. The method deviates from the standard practice of topsoil removal and storage by protecting undisturbed soil resources in-place. This experiment will test the practicality of "storing" topsoil materials in-place. It is thought that slope stability and vegetation establishment will be enhanced by retaining the original characteristics intact.



Figure 3.14: Fill material is placed on the geotextile mat. West Ridge Mine.

A geotextile mat was placed over the intact, undisturbed soil surface, then covered with fill materials that did not contain toxic or hazardous material. Fill materials will remain in-place for the duration of the mining operation until final reclamation. During final reclamation, the fill will be removed, re-exposing the geotextile layer. Then, the geotextile fabric will be removed to expose the original soil surface. The soil surface will then be treated by loosening the soil surface. Finally, the soil surface will be seeded and revegetated.

Although the storage of topsoil underneath fill materials is similar to storage of deeply buried topsoil in a stockpile, it is not the same.

The in-place preservation technique offers several environmental benefits:

- Soil remains intact throughout storage, without losses to wind and water or contamination by coal fines, road salts, or weed seeds.
- Rocks, roots, and soil cohesiveness remain to encourage vegetation establishment and to reduce the potential for erosion and slope failure.
- Natural diversity of soil type and depth will encourage plant diversity during reclamation.
- Undisturbed slopes and native in-place soils naturally blend into the surrounding environment.

Soil Placement

Establish the final grade according to the reclamation plan. Complete all channel and riprap placement and wildlife enhancements (rock piles) prior to topsoil replacement and seeding.

Time topsoil replacement to coincide with the most beneficial seeding window. In Utah, this is usually September through November ([Chapter 4, Section 2](#)). Topsoiling may require a temporary seeding of fast-growing cover crops, such as oats, wheat, and barley, to provide erosion control and prevent weed establishment ([Part 2, Section 2](#)).



Figure 3.15: Rockpile for wildlife enhancement. Cottonwood Mine.

The preferred rooting zone depth is two feet with the top twelve inches being topsoil or substitute topsoil. However, a diverse landscape is dependent on diversity of soils and soil depths. Soil quantities placed over the entire site will vary according to:

- Topsoil availability - volume of stockpiled or live haul topsoil
- Substitute topsoil availability - volume of substitute topsoil identified and stored
- Plant species to be planted - dictates needed topsoil replacement depths
- Proposed land use - dictates plant species to be planted
- Steepness of slope - impacts access, stability and methods for topsoil placement
- Quality of overburden and fills - determines total needed cover requirements

Alleviating Soil Compaction



Figure 3.16: Use track equipment to reduce compaction. Summit #1 Mine.

The earthmoving equipment used in most surface mining operations is not designed to produce the low ground pressures needed to avoid compaction. Scrapers produce the most compacted soils. Compaction can be kept to a minimum if the scrapers traverse the replaced soil materials as little as possible. Graders have a lower wheel bearing pressure than scrapers. Other options include front-end loaders for picking up the soil and dump trucks for delivery and transport. Bulldozers may be

used for leveling and track hoes for soil placement and surface roughening. Any method that reduces equipment traffic during soil removal and redistribution is desirable for lessening soil compaction.

Ripping, pocking, deep gouging, extreme roughening and surface scarification techniques (Part 2, Section 1) are used to ensure a proper bond between the soil/spoil interface and to alleviate compaction in both the soil and spoil. Apply the following techniques before or after topsoil placement:



Figure 3.17: Extreme surface roughening breaks up compacted layers. Crawford Mine.

Surface Roughening Before Topsoil Replacement

- Eliminates the slip zone between the regraded spoil and replaced soils
- Breaks up compacted layers that have been developed within the regraded spoil
- Promotes moisture and root penetration

Use where:

- Spoil quality is classified as poor growth medium
- Spoil and topsoil mixing would be detrimental to vegetation establishment
- Topsoil replacement depth is too great to allow penetration into the regraded spoils

Surface Roughening After Topsoil Replacement

- Single, deep operation to penetrate the entire soil/spoil interface and profile
- Leads to fewer compact lower horizons
- Creates micro-sites favorable for seed germination

Use where:

- Spoil quality is classified as acceptable growth medium
- Spoil is compatible for mixing with replaced topsoil
- Topsoil replacement depth is shallow enough to allow penetration into the regraded spoils
- Topsoil replacement is deep.

Surface Preparation

All final surface and seedbed preparation should result in a roughened soil surface. In Utah, surface roughening is a key factor in reclamation success for vegetation establishment, surface stabilization, and erosion control. Surface roughening has broad application for reclamation in varied climate, soils, and topography. Soils must be in a friable condition prior to implementing any soil surface preparation techniques. When soil amendments are required, apply them before roughening the surface.

Pocking, Deep Gouging and Extreme Roughening

Extreme surface roughening creates microbasins by using a backhoe or trackhoe shovel. The trackhoe shovel is used to dig, poke, or push basins with a minimum elevation of eighteen inches. These basins should be 1 1/2 to 2 feet deep and have the width of the bucket. This allows the basins to be up to four feet wide. The most common construction method is to dig a bucket load of soil and then drop it two to three feet above the soil surface.



Figure 3.18: The soil surface is roughened, seeded and then hydromulched. Sunnyside Mine.

The process is repeated in a random and overlapping pattern, making it impossible for water to flow down slope. Finished roughened soils should be difficult to walk over. On poor, shaley sites, such as the Mancos Shale, the pocks can fill with sediment within a short time period. Therefore, the pocks should be as large as possible and resemble the moguls of a ski slope. Conversely, on sites with adhesive soils, the pocks should not be too large, because they would fill with water. Straw, alfalfa, or hay can be spread during roughening and anchored to the soil surface by jabbing

the materials into the soil surface or tacking them with a hydromulch slurry.

Because a drill seeder cannot be used on such rough surfaces, seed must be broadcast by hand or hydroseeded ([Chapter 4, Section 2](#)). In areas with extremely dry and loose soil, it may be advantageous to wait until the soil has settled before starting the seeding process. One method is to broadcast half the seed immediately and broadcast half the seed after the soil settles.

Ripping

Ripping is used as a soil-roughening technique in areas too large to economically roughen by gouging with a backhoe. Ripping is also used to break compacted layers of soil. Ripper shanks should be at least two feet long. Rip compact soil when it is relatively dry to permit shattering beneath the surface. The equipment travels along the contour of the slope, ripping to a depth of two feet or more.



Figure 3.19: Deep ripping breaks up compact soil. Summit #1 Mine.

Note: The distance between rippers should be equal to the depth ripped.

Lift the ripper from the soil every ten to twenty feet to reduce the chance of creating long water pathways subject to catastrophic breaching. Spread seed simultaneously with the ripping operation if a broadcast seeder is attached to the rear end of the ripping equipment. Soil amendments or surface mulch may be incorporated into the soil during the ripping operation.

Discing, Cultipacking, Harrowing

Discing, cultipacking, and harrowing are not recommended in Utah's arid climate, because they create pasture-like conditions that subject the soil to wind and water erosion. Discing is accomplished by pulling disks attached to gangs with a farm type tractor. Discing is used as secondary tillage if ripping has left large clods. Harrowing is also used to breakup large clods. Harrows consist of disks, tines, or other scarifying tips. Cultipacking finely pulverizes the soil and packs the soil surface uniformly.

Contour Furrowing

Contour furrowing and terracing have limited use for reclamation in Utah. The major limitation is that contour furrows need to be used on slopes less than 10%. Furrows are placed three to five feet apart, 1½ to 2½ feet wide, 1 foot deep, and dams must be placed every four to twenty feet, depending on slope of land. Visual scars from the straight-line furrows can remain for decades, making the reclamation appear unnatural.



Figure 3.20: Terraces are used to reduce slope length on these reclaimed mine dumps. Goldstrike Mine.

Terraces are like contour furrows on a much larger scale. Terraces provide channels that run nearly perpendicular to the slope, trapping sediment and conveying excess water off the site in a controlled manner. Terraces are most suited to large mine dumps and spoil piles. If used, terraces should be designed by a hydrologist to determine adequate sizing and drainage gradient.

Fertilizers and Soil Conditioners

Replaced topsoil and substitute topsoil materials may need amendments both to increase the supply of nutrients and to improve the physical, chemical, and water-holding characteristics of the soils. Soil amendments include chemical fertilizers, composted sewage sludge ([Chapter 2, Section 2](#)), manures, and chipped wood byproducts. Incorporation of chipped wood byproducts, straw or hay mulches improves water infiltration, and reduces soil temperatures. Composted sludge and manures not only supply primary plant nutrients, such as nitrogen, phosphorus and potassium, but are also excellent soil conditioners. The added organic material restores soil tilth and microbial populations.

Fertilizer Application Rates

The nutrient requirements of native plants are less than those of agronomic crops, upon which most fertilizer recommendations are based. As over-application of fertilizer increases weed growth, fertilize only after testing detects a major soil deficiency and only use slow release fertilizers. Application rates should be calculated for dryland conditions, well below agricultural rates.

Fertilization Methods

Solid fertilizers are broadcasted and liquid-based fertilizers are sprayed on the soil surface. Incorporate the fertilizer into the rooting zone by surface roughening. Otherwise, the nitrogen is lost to the atmosphere and the phosphorus is fixed in the very top few centimeters of the soil.

Soil Surface Stabilization

The Revised Universal Soil Loss Equation (RUSLE) model shows that length and steepness of a slope, combined with the soil type and precipitation influence annual soil loss. The implementation of the following techniques can reduce annual soil loss:

- Applying favorable cover, such as mulch, rocks, and shrub debris
- Incorporating management practices like concave slopes and extreme roughening
- Eliminating compaction by ripping
- Limiting the exposure of disturbed land during periods of intense rainfalls and snowmelt

For more discussion on RUSLE ([Chapter 3, Section 4](#)).



Figure 3.22: Biosolids additions to tailings. Kennecott Tailings Facilities.



Figure 3.21: Uncontrolled erosion in unconsolidated reclaimed drainage. JB King Mine.

Biosolids

As with other organic matter additions, the use of biosolids (composted sewage sludge) builds soil structure and makes the surface less hard, which improves the retention of water helping to control erosion.

Why use biosolids?

- Biosolids build microbial populations and biological activity in sites that have a deficit of topsoil, such as mine tailings, waste rock sites, and overburden.
- Biosolids act as a slow release fertilizer, providing available nitrogen over a five-year period. This makes nitrogen not as available to fast-growing, annual weeds.
- Biosolids mixed with fine material such as fly ash or tailings create friability and permeability, improving the wetting and drying characteristics of the tailings.
- Biosolids application may be economically more feasible than using imported soil material.
- Biosolids application may lower the pH by about one unit.

For protection of surface and groundwater, some constraints must be considered when using biosolids. These restrictions are covered in the 40 CFR 503 (Code of Federal Regulations) regarding land application of sludge.

- Biosolids must not be applied to frozen soil or snow-covered ground.
- Biosolids may not be applied to steep slopes that contain fine material and are therefore prone to erosion.
- There must be a minimum of five feet depth to the seasonal water table and a thirty-foot buffer zone for surface waters.
- Biosolids must not be applied to low pH soils, as the metals in the biosolids will become mobile.

Requirements of biosolid land applications are established by the Code of Federal Regulations (CFR) and the Utah Annotated Code (UAC). The Utah Division of Environmental Quality (DEQ) is the permitting authority under UAC R317-8. Communication with DEQ is the responsibility of the sewage treatment plant operator. The treatment plant operator is responsible for notification of DEQ when biosolids are land applied. This information is itemized in the operating permit of the treatment plant

Biosolids are classified according to degree of pathogen reduction (Class A or B) and concentrations of heavy metals. Analysis of the sludge is the responsibility of the treatment plant operator. The metals being monitored are As, Cd, Cr, Cu, Pb, Hg, Mo, Ni, Se, and Zn.

Class A biosolids which do not have heavy metal loading rate restrictions can be applied to reclamation sites without monitoring (40 CFR 503 Subpart B) and without regard for the surface and groundwater restrictions outlined above. Biosolids are applied at agronomic rates unless otherwise authorized by DEQ. Up to five times the agronomic rate may be authorized for a one-time application (Schmitz 1999).

Note: Agronomic rates are based upon the nitrogen requirement of the plant species to be grown. For example, the nitrogen requirements of some grasses have been determined to be 300 lbs/acre for fescue and 275 lbs/acre for perennial ryegrass (Phillips 1996). This information, along with the plant available nitrogen in the biosolids (ammonium, nitrate, nitrite, and mineralized organic nitrogen), is necessary to evaluate the agronomic rate.

Agronomic Rate in Tons biosolids/acre = (crop N requirement in tons/acre)/(Available N in tons per ton of biosolids)

Authorization by the Division of Water Quality of the Department of Environmental Quality is required prior to applying biosolids at levels above agronomic rates.

Levels above agronomic rates have been used recently in the state of Utah on two mining related reclamation projects: J.B. King waste rock reclamation (a coal mine site) and the Kennecott Biosolids Demonstration Project (a minerals tailings site). Following a five-year study at Kennecott, the recommended application rate of biosolids was twenty tons per acre. (McNearney 1998) At J.B. King, the application rate of biosolids was twenty four tons per acre. The biosolid layer, approximately two inches thick, was worked into the surface layer of the soil before seeding.

Mulches

Mulch is a protective layer. It can be organic or inorganic. Straw, hay, and wood fiber mulch temporarily stabilize the surface and reduce erosion. They are effective for a few years and then decompose. Rock is a permanent surface soil stabilizer. Consider using rock when the established vegetation does not control erosion ([Part 2, Section 3](#)) for greater detail on the various mulch material and application methods.



Figure 3.23: Incorporating mulch on test plots. Banning Loadout.

Table 3.3: Mulch materials for use on disturbed areas.

Mulch Type	Application Rate	Method of Application	Anchoring Method	Notes
Grass Hay	1 to 2 tons/acre	Blower, hand	Crimping, Chemical Binder, Netting	Certified Noxious Weed Free
Straw	1 ton/acre	Blower, hand	Crimping, Chemical Binder, Netting	Certified Noxious Weed Free
Alfalfa	1 to 2 tons/acre Blower, hand	Blower, hand	Incorporated into soil surface	Certified Noxious Weed Free, Pulverizes in blower, better C:N ratio
Erosion Control Matting	entire area	Hand per Manufactures Specification	Staples, Surveying stakes, trench top of matting	Lay loosely, snake mortality, breaks down in sunlight
Wood Fiber Hydromulch	1/2 to 1 ton/acre	Hydromulcher	Chemical binder @ 80 to 120 lbs./acre or manufactures rate	Not as long lasting as straw or hay
Cover Crop (Oats, Barley)	15 to 80 lbs/acre	Drill or Broadcast		Plant perennials following season
Rock	2 to 3 inches		Leave on surface or mix into top 6"	Use on steep slopes, in arid regions

Problem Soils

Selective handling and treatment of acidic, toxic, saline or sodic overburden materials will protect groundwater quality and plants after soil replacement.

Options include:

- Segregation and burial beneath non-toxic materials
- Remediation treatment to eliminate the impact of toxic materials on water quality
- Tolerant plant species

The Surface Mining and Reclamation Act of 1977 requires that a minimum of four feet of suitable growth medium is replaced over mine waste rock, refuse material, bedrock, concrete, or acid/toxic forming materials. This is also the best management practice for all mining operations in Utah.

Selenium

There are two main issues concerning selenium contamination in surface mine reclamation. These include selenium uptake by crops, forages, or native plants, resulting in selenium toxicity to animals and selenium contamination of surface water and groundwater. Selenium is often associated with sulfide minerals or rocks found in mine spoil, waste rock, and mine-processing waste. Under alkaline conditions, insoluble selenium minerals are oxidized to more soluble selenium species through natural weathering

processes. Soluble selenium species accumulate in surface soils and are the source of selenium contamination in surface mine reclamation, in bodies of standing water, and in poor drainage areas. As a result, selenium may be leached into ground and surface water.

Although selenium is not considered an essential element for plant growth and development, plants bio-accumulate this available selenium. Plant growth is not retarded by selenium concentrations commonly encountered in soils. Selenium in low levels is essential to animal nutrition. However, toxicity occurs when animals consume plants containing 3 to 20 ppm over a long period. Acute toxicity occurs when animals consume vegetation containing 100 ppm or greater (Williams and Schuman 1987). If selenium is present, grazing by domestic livestock is not advisable.



Figure 3.24: Surface crust of Mancos Shale. Emery County.

Selenium mobility is high in neutral to alkaline soils. In slightly acid soils that are oxidized, selenium mobility is lower. In wet, acid, or humus-rich soils, selenium is generally immobile and bio-availability is very low.

Boron

Boron is an essential micronutrient for plant growth and required in very small concentrations. Boron is quite mobile in soils, leaching out of soils in humid climates and concentrating in the surface of arid and semi-arid climates. As a general rule, boron availability is low in both acidic and calcareous soils of coarse texture. Leaching accounts for the boron deficiency in acidic soils. In calcareous soils, the deficiency is due to strong adsorption and precipitation as relatively insoluble calcium borate salts.

In contrast, Boron toxicity is most commonly found in alkaline soils, mine waste, spoils, and coal of arid regions. These materials often contain high levels of sodium that form soluble sodium-borate salts. Low rainfall allows soluble borate salts to accumulate in the surface layer at concentrations toxic to plants. Boron can be responsible for reclamation failure in arid, alkaline locations.

Boron toxicity to agricultural plants occurs when soils contain more than 5 ppm of hot-water-soluble boron. Many native plant varieties are adapted to boron levels in excess of 5 ppm. Therefore, soil and overburden containing more than 5 ppm of hot-water-soluble boron require special revegetation considerations (William and Schuman 1987).

Acid-Forming Materials

Acid formation occurs when sulfide-bearing minerals such as pyrite (FeS_2),



sphalerite (ZnS), and chalcopyrite (CuFeS_2) are exposed to air and water. In the process, sulfur products and metals are released into solution. The bacteria *Thiobacillus ferro-oxidans* is the biological catalyst in the oxidation reaction. For an excellent discussion of the topic, read "An Introduction to Acid Rock Drainage," and "The role of Micro-organisms in Acid Rock Drainage," by Chris Mills, available online at <http://www.enviromine.com>.

Figure 3.25: Typical acid mine drainage.

Acid formation:

- Lowers soil pH
- Increases concentrations of Al_3^+ and H^+ cations, creating more acidity
- Solubilizes trace metals (Fe, Al, Mn) to toxic levels, resulting in competition for soil exchange sites with other plant nutrients (N, P, K).
- Binds nutrients, such as P with Fe and Al
- Increases ratios of H^+ to Ca_2^+ and Mg_2^+ , resulting in destruction of roots
- Inhibits nitrification, like the microbial conversion of NH_4^+ to NO_3^-
- Increases salinity, or, electrical conductivity (EC)



Figure 3. 26: Acidic soil created by mine tailings.

A popular idea is that acidic coal mine drainage occurs only in the eastern U.S., but it can also occur in the West. Acid-forming wastes have been brought to the surface at the Boyer Mine in Summit County, Utah and the Starpoint Mine in Carbon County, Utah and in Wyoming, New Mexico, Texas, and Montana (Boon and Smith 1985).

Keep the exposure of acid-producing material to a minimum.
Treat and bury the waste

immediately. Grade the surface to promote runoff rather than infiltration. Balance the need to eliminate water and oxygen transport into the spoil with vegetation establishment. To treat with amendments, gather information about acid-base potential (Sobek, et.al. 1978), moisture content (Gardner 1986), and particle size.

As explained in the following paragraphs, acid-generating waste is reclaimed through:

- Burial under four feet of cover
- Treatment with amendments
- Use of acid-tolerant plant species

Figure 3.27: Acidic mine waste burial site. Boyer mine.



Burial of the acid forming materials under four feet of non-acidic or non-toxic material will reduce oxygen penetration to the pyritic spoil and diminish the acid production. The deeper the burial of acid forming material, the better the seal. The non-toxic cover material will form the root zone. It may be topsoil or spoil capped with topsoil. To avoid degradation of the topsoil by the upward migration of acidic salts, place a capillary barrier between the acid-forming waste and the rooting zone.

Calcium or magnesium-carbonate materials neutralize the acidity formed by excess sulfate in solution. Where iron-sulfide minerals in coal are overlain by calcareous rock, the mine drainage is neutral rather than acidic (Cravotta et.al., 1990; Skousen and Larew, 1991). Where calcareous overburden is lacking, the acid-forming materials can be amended with imported alkaline materials such as limestone (CaCO_3) and lime $[\text{Ca}(\text{OH})_2]$, blast furnace slag (CaSiO_3), fly ash, and cement kiln dust (CaO). The amount of calcium carbonate to apply is calculated based upon the total sulfur and calcium carbonate content of the waste (Sobek, et.al. 1978; Cravotta, et.al 1990; Skousen 1991).

Organic matter amendments delay pyrite oxidation by consuming oxygen during decomposition. Organic matter also removes iron, aluminum and other metals by adsorption and complexation. Organic materials have been used in Anoxic Limestone Drains (Skousen 1991) and as filters for acid mine drainage in alpine settings (Fantin 1996). Organics react with metals, creating complex associations without creating chemical sludge, which is characteristic of oxidized drainage from lime-treated materials. (Fantin 1996; Skousen and Sencindiver 1988).

Finally, sodium laurel sulfate, an anionic surfactant, may be applied directly to pyritic material to destroy *Thiobacillus ferro-oxidans*. Kleinmann and Erickson, 1983, provide a detailed summary of application procedures and other considerations of the method.

Commercially available plant materials like "Summit" Louisiana sage (*Artemisia ludoviciana*) from the Upper Colorado Environmental Plant Center have been derived from acid-tolerant genotypes (Fisher et. al. 1989). Accessions of genotypes found growing on the acid mine waste could evolve into a third management strategy for remediation. A useful publication for evaluating plant adaptations is Wasser 1982.

Listed below are plant species that have adapted to acidic conditions (Fisher et.al. 1989; Morrey 1993). These recommendations are based on the authors' research and not on research specific to Utah mining conditions. Some species listed may not be native to Utah.

- *Carex eleocharis*. (needle leaf sedge)
- *Eriogonum sp.*
- *Juniperus horizontalis*. (creeping juniper)
- *Rosa arkansana*. (prairie rose)
- *Schizachyrium scoparium*.(little bluestem)
- *Thermopsis rhombifolia*. (prairie thermopsis)

Creeping juniper is particularly important in stabilizing soils, because of its form. Thermopsis, eriogonum, needle leaf sedge, and prairie rose play an important role in stabilization due to their rooting systems.

Listed below are several tolerant grasses (Morrey 1993). These recommendations are based on the authors' research and not on research specific to Utah mining conditions. Some species listed may not be native to Utah.

- *Agrostis stolonifera* (weeping bent grass)
- *Cynodon aethiopicus*
- *Dactylis glomerata* (orchard grass)
- *Digitaria eriantha*
- *Eragrostis chloromelas* (boer lovegrass)
- *Eragrostis curvula* (weeping lovegrass)
- *Eragrostis gummiflua*
- *Festuca arundinacea* (tall fescue)
- *Hyparrhenia hirta*
- *Lolium perenne* (perennial ryegrass)
- *Paspalum dilatatum* (dallis grass)
- *Pennisetum clandestinum*.

Saline-Alkali and Sodic Soils

Excess soluble salts in soil create a two-fold problem for plant growth. The soil solution contains so much salt that the osmotic potential is very low and plant roots cannot draw water from the soil. In addition to this, the excess sodium in the soil physically alters the clay lattice structure, reducing permeability of the soil. The excess sodium destroys the soil structure by dispersing the soil particles. Soil pore spaces are eliminated and the soil becomes impermeable to water. These effects are more pronounced in fine-textured soils than in coarse-textured soils.

Frequently, the salts creating problems are the cations (sodium, calcium and magnesium) and the anions (chloride and sulfate). Analyses that are used to characterize salinity and sodicity are pH, Electrical Conductivity (EC), and Sodium Absorption Ratio (SAR). The SAR is calculated by the ratio of sodium to magnesium and calcium (USDA

$$\text{SAR} = \frac{\text{Na}^+}{\sqrt{\frac{\text{Ca}^{++} + \text{Mg}^{++}}{2}}}$$

This formula represents the concentrations in milliequivalents per liter of the respective ions.

Soils are classified as saline, sodic, and saline-sodic as shown in Table 3.4.

Table 3.4 Soils classification.

Classification	EC (mS/cm)	ESP (%) ¹	Typical pH	Resulting Soil Structure
Saline	>4	<15	<8.5	Good
Sodic	<4	>15	>9.0	Poor
Saline-sodic	>4	>15	<8.5	Fair-good

Saline-alkali soils have an excess of soluble salts and an excess of sodium. They are characterized by an EC reading greater than 4.0 mmhos/cm and an Exchangeable Sodium Percentage (ESP) of greater than 15% (USDA Salinity Laboratory, 1954).



Figure 3.28: Alkali soil. Emery Deep Mine.

Nonsaline-alkali or sodic soils are those which have an EC of less than 4.0 mmhos/cm, an ESP of greater than 15%, and a pH greater than 8.5. Sodic soils present physical limitations to soil structure by causing clay swelling, particle dispersion, and sealed soil pores, resulting in reduced drainage and air infiltration. Sodic soils also have the potential to accumulate toxic levels of sodium salt within plant tissue. Sodic soils

are alkaline. In alkaline soil solutions, the plant available iron is limited, leading to chlorosis.

Sodic soils can be amended with gypsum or other soluble calcium salts only if there is adequate rainfall or irrigation water and drainage to leach away the sodium salts that are freed from the soil as the calcium replaces it on the soil exchange site. Sulfuric acid treatments on calcareous sodic soils have produced lower sodium adsorption ratios, more soluble calcium and magnesium, and lower pH values than the use of gypsum (Mace et al. 1999). Another strategy is to amend the sodic soil with sulfuric acid prior to topsoil application (Gould 1982) to increase the infiltration rate and water holding capacity of the soil, allowing deeper root penetration.

Where irrigation is impractical, the use of sodium-tolerant plant species and the application of organic matter to lower the SAR and to improve the physical condition of the soil is advised (Fresquez et al. 1982). Revegetation efforts improve when a layer of imported topsoil is placed over the saline overburden to reduce salts in the seed germination zone. Over time, as plants become established, the sodic soil becomes more permeable because of the voids created by root spaces.

The most common approach to saline-alkali or sodic soils is to bury the material to reduce contact with the wetting front and limit the upward migration of the salts.

Plant tolerance of saline-alkali or sodic soils varies by species. The Plants Database at <http://plants.usda.gov> is helpful for selecting species. Salt tolerant and moderately tolerant species are listed in Franklin, et al. 1987. Many of these species are native to Utah, but in all cases, it is essential to be sure the species being used are adapted to the site conditions. Tolerant and moderately tolerant plant species are listed below.

Tolerant Plant Species

- *Puccinellia* sp. (alkali grass)
- *Sporobolus airoides* (alkali sacaton)
- *Agrostis stolonifera*, *palustris* (creeping bentgrass: Seaside, Arlington, Pennlu, Old Orchard varieties, Redtop)
- *Poa trivialis* (rough stalk bluegrass)
- *Festuca arundinaceae* (tall fescue: Alta and Kentucky 31 varieties)
- *Festuca rubra* (creeping red fescue: Saltol, Ruby varieties)
- *Alopecurus arundinaceus* (creeping meadow foxtail)
- *Distichlis stricta* (inland saltgrass)
- *Agropyron elongatum* (tall wheatgrass: Jose, PI-109452, Mandan 1442, NDG-1)
- *Elymus cinereus* (basin wildrye)
- *Elymus junceus* (russian wildrye)

Moderately Tolerant Plant Species

- *Poa canbyi* (canby bluegrass)
- *Poa pratensis* (Kentucky bluegrass: Adelphi, Ram I, Fylking, Nassau varieties)
- *Bromus inermis* (bromegrass: Lincoln, Polar varieties)
- *Phalaris arundinacea* (reed canarygrass)
- *Trifolium repens* (Merit ladino clover)
- *Lolium perenne* (perennial ryegrass: Norlea, Common, NK 200 varieties)
- *Agropyron* sp. (wheatgrass)
- *Ceratoides lantata* (winterfat)
- *Atriplex confertifolia* (shadscale)
- *Atriplex canescens* (fourwing saltbrush)
- *Suaeda* sp. (suaeda)
- *Kochia americana* (gray molly)
- *Sarcobatus vermiculatus* (greasewood)
- *Atriplex corrugata* (mat saltbush)
- *Atriplex gardneri* (gardner saltbush)
- *Gravia spinosa* (spiny hopsage)
- *Phragmites australis* (common reed)
- *Medicago sativa* (alfalfa)
- *Asparagus officinalis* (asparagus)

Erosion

Disturbance of soil due to oil, gas, and mining activities will change the distribution, quality, and quantity of water runoff. These landform changes will subsequently affect the rate and pathways of water to stream channels. The impacts of drilling, pumping, and mining practices may not be confined to the land on which those activities occur. Neighboring landowners can be affected through increased soil erosion, sediment deposition, water pollution, and flooding. Entire communities can be affected by the loss of water quality in watersheds that they depend on for culinary and irrigation water.

Using good soil and water conservation practices can reduce the effects of mining activities on offsite resources. Best Technology Currently Available (BTCA) and Best Management Practices (BMP) are terms used to describe erosion control methodologies. The ultimate goal of any sediment control measure is to prevent erosion from starting. For example, vegetation establishment, a BMP, is the most efficient way, or BTCA, to prevent or minimize erosion and is the ultimate goal of most all sediment control measures. During active mining operations and until reclamation vegetation is established, additional measures are needed to prevent sediment from leaving the site. The BTCA for these situations is sediment retention using the BMP's such as sediment ponds.

Erosion Process

Soil erosion is the removal and subsequent loss of soil by the action of water, ice, wind, and gravity. Soil erosion is a process that occurs naturally. Utilization and disturbance of the land by human activity significantly increases the rate of soil loss. Unprotected construction and mining sites can have annual soil loss rates of more than 300 tons per acre (USDA).

Soil erosion by water occurs in the following three phases:

1. Particle detachment
2. Sediment transport
3. Sedimentation or sediment deposition

In the particle detachment phase, soil particles are detached from the parent soil mass by falling raindrops or by the shear forces of runoff. In the second phase, sediment transport, particles are moved down slope or carried in a stream. The ability of the runoff to transport the detached particles is a function of the runoff velocity. The third phase of the erosion process, sedimentation, occurs when the velocity of the runoff is slowed and the load carrying capacity decreases, causing some or all the sediment to deposit. Generally, the larger, heavier particles deposit first and then the finer, smaller particles deposit further down slope.

Types of soil erosion caused by water are:

- Splash
- Sheet (inter rill)
- Rill
- Gully
- Stream and channel

The erosion potential for a given area is dependent on several factors or characteristics which include:

- Soil type
- Topography
- Climate
- Soil cover
- Antecedant conditions

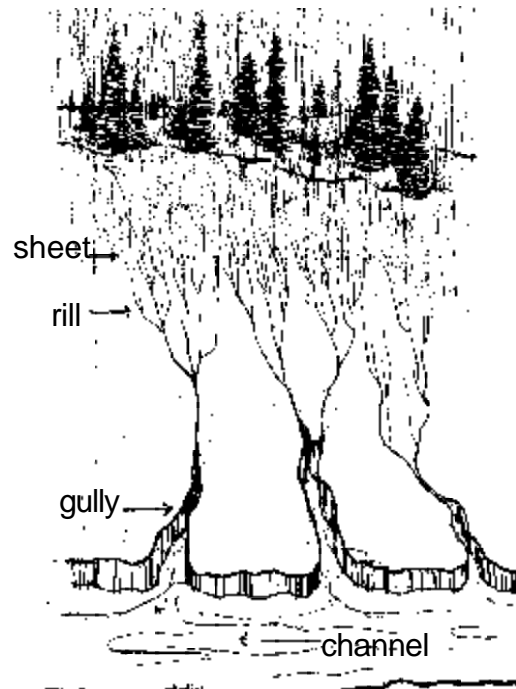

Figure 3.29: Phases of soil erosion.
(redrawn by Jenny Suflita)

The Revised Universal Soil Loss Equation (RUSLE) illustrates how these characteristics interact to reduce erosion and how each factor must be considered when planning for the stabilization of disturbed sites.

The RUSLE equation is $A = R K L S C P$, where

A = average annual soil loss in tons per acre per year

R = the rainfall erosivity factor or average annual total of storm energy by intensity, including snowmelt (based on the 22-year average)

K = soil erodibility factor, which is measured or estimated for each soil and based upon soil properties (soil with a high percentage of silt is more erodible than clay)

LS = hillslope length and gradient factor, which accounts for the effect of topography on erosion (increasing slope length and steepness will increase erosion)

C = cover management, which represents the effect of vegetation, management, and erosion control practices (surface roughness will lower this factor)

P = support practice factor, which is the ratio of soil loss with practices like concave slopes and contour ripping

The RUSLE model shows that the length and steepness of a slope, combined with the soil type and precipitation, influence annual soil loss. The implementation of the following techniques can reduce annual soil loss:

- Apply favorable cover, such as mulch, rocks, and shrub debris
- Incorporate management practices like concave slopes
- Eliminate compaction by ripping
- Limit the exposure of disturbed land during periods of intense rainfalls and snowmelt

The RUSLE program and the supporting database set are available as a self extracting, zipped executable on the RUSLE official website at <http://www.sedlab.olemiss.edu/rusle>.

Site Specific Erosion Control Plan

When developing an erosion control plan, sufficient site-specific resource is required. Information on the following site characteristics should be collected and evaluated:

- Acreage
- Soils
- Drainage pattern
- Rainfall data
- Nearest receiving water
- Groundwater information

Maps

One way to collect information about site characteristics is from maps. Both topographic maps and aerial photographs can be used. ([Resources](#))

Soil Information

Soil information is directly related to sediment transport. Knowing about soil textures and erodibility, the K factor, is essential to creating a design plan. The most accurate and useful soil information is data collected on-site by a qualified soil scientist ([Chapter 3, Section 1](#)). Soil survey information provided by the Natural Resources Conservation Service can help determine soil textures and erodibility factors.

Drainage Pattern

Drainage patterns are pathways that snowmelt and storm water runoff follow onto, through, or off a site. Drainage pattern identification is determined from site survey information, topographic features, maps, and observation of the site. The acreage of each drainage area is needed for design of the sedimentation control structures.

Rainfall Data

Rainfall data is needed when designing sedimentation structures such as sediment basins, detention/retention ponds, and diversion ditches. The types of data needed may include 10 year 24 hour storm event, 100 year 6 hour storm event, and storm return periods. Rainfall data can be found at <http://www.wrcc.dri.edu/pcpnfreq.html>, and in the National Oceanic and Atmospheric Administration Atlas 2, published in 1973.

Receiving Waters

Identify receiving waters by name, location, and distance from the site. Receiving waters in Utah are streams, rivers, lakes, springs, and wetlands. Intermittent and ephemeral streams are considered receiving waters.

Depth to Groundwater

Determine the depth to groundwater in order to prevent groundwater pollution. Coarse soil and a high water table create a great potential for groundwater pollution, especially when coupled with a water treatment design of infiltration and sedimentation. Culinary water wells in close proximity to the site should be identified. Some of this information may come from the Department of Natural Resources, Division of Water Rights, Utah Geological Survey, and U.S. Geological Survey.

Construction Detail

Maps and plans must address the different stages of construction. The construction stages can be divided into three separate phases:

1. Initial clearing phase
2. Intermediate grading phase
3. Final stabilization of operation or reclamation phase

Perimeter controls usually coincide with the initial clearing phase. Earth-moving activities and soil exposure are greatest during the intermediate grading phase. Temporary erosion controls must be implemented in incremental stages as construction progresses. The last phase of erosion control will depend on the operation or reclamation plan, but may include short term and long term controls.

Erosion and Sediment Control Methods

Successful erosion control begins with appropriate planning. However, even the best plans must be modified during or after installation. The erosion control plan should permit maximum flexibility to allow modification to the plan. Erosion control technologies can reduce, but not eliminate, soil erosion.

Follow these basic principles of erosion prevention and control:

- Keep disturbed areas small and practical.
- Avoid or minimize the disturbance on highly erodible soils.
- Reduce exposure during expected wet seasons.
- Protect disturbed areas from the runoff of adjacent areas.
- Retain sediment within the site. To accomplish this, use several small BMP's in combination with a large BMP to reduce maintenance.
- Keep runoff quantities and erosion velocities low.
- Reduce exposure time. Stabilize, vegetate, and protect from raindrop and runoff as soon as practical.
- Grade all slopes to concave or complex slope shapes.
- Reduce slope lengths or gradients.

Table 3.5 sediment and erosion control methods.

Short Term Constructions	Short Term Operations	Long Term Reclamation
Straw or hay mulch	Temporary seeding	Slope Shape
Strawbale barrier*	Straw or hay mulch	Straw or hay mulch
Silt Fence barrier	Filter	Extreme surface roughening
	Diversions*	Permanent seeding
	Temporary sediment* trap	Erosion-control matting
	Sediment pond*	Rock mulch
	Slope drains*	
	Check dams*	
	Outlet protection	
	Inlet protection	

*Maybe appropriate for initial reclamation period but will require maintenance and subsequent removal.

Diversion and retention/detention structures should be designed by a professional engineer or other qualified individual. The installation of these structures will need to be scheduled into the site development and reclamation schedule.

Often, a combination of temporary and permanent techniques is needed to adequately control sediment and erosion. In addition, several small structures may function more effectively than a single large structure. Several small structures in combination with a large structure may reduce the maintenance and cost of sediment removal. The type and

combination of techniques will depend on several factors such as soil texture, slope steepness and length, size of disturbed area, frequency and intensity of rainfall events, length of time until vegetation establishment, and distance to surface water features.

Maintenance Plan

Evaluation and subsequent modification of the erosion control structures may be required to fit the BMP to your site. Erosion control structures must be regularly monitored and maintained to be effective and function properly. The following tips can help with a maintenance plan:

- Do not block a natural drainage way.
- Visit the site during and after storms.
- Place control measures out of the way of operations.
- Make field modifications of the structures where necessary.
- Provide access for maintenance and removal.
- Plan where sediment will be placed after structure clean-out.
- Use a sediment marker in sediment ponds to indicate clean-out level.

The Activity Checklist in the [Resources](#) section of this manual can be used as a tool to help a contractor or foreman manage the erosion control practices.

Roads

Roads are considered the single largest contributor of sedimentation to watersheds. Roads to oil, gas, and mining sites are often left after operations for post-extraction land use. Control of water flow from the road surface and associated cut and fill slopes is essential to reducing erosion and subsequent sedimentation. The rules to prevent or minimize sedimentation from roads are:



Figure 3.30: Uncontrolled water flow resulted in excessive grading on this road used for logging Carbon Co. activities.

- Minimize road construction by using existing roads where possible.
- Locate roads in stable areas.
- Design roads that are reclaimable.
- Design roads for their intended use. For example, a 2-track road may be adequate for some types of exploration.
- Balance cut and fills. Avoid importing material.
- Avoid sustained excessive grades.
- Use durable surfaces such as pavement.
- Design road surface slope to utilize natural drainages. Use techniques such as in-sloping, out-sloping, and changing of grade.

- Design cross culverts and ditches to complement natural drainage.
- Reduce runoff from above the road.
- Limit road construction during periods of excessive moisture or frozen ground.
- Stabilize cut and fill slopes with vegetation as soon as possible.
- Install road drainage at the time of road construction.
- Install water bars to prevent large volume of flow from accumulating.

Remove water from the road surface as soon as possible. Out-slope, in-slope, or crown the road surface to complement the surrounding drainage and utilize non-erosive surfaces. Out-sloped roads drain water off the road and road fill in a low-energy, unconcentrated flow. Out-sloped roads are advantageous because they do not require a system of culverts and ditches. However, they can only be used in limited conditions. Roads can be out-sloped if the fill is made up of stable, non-erodible soils and if there is not slippery mud or ice present.

In-sloped roads concentrate water on the cut roadside and require drainage ditches and associated culverts to carry the water away from the road. Ditch gradients of two to six percent are required to keep collected water moving but not too steep for excessive erosion to occur. This is dependent on the soil type. The concentrated water collected in the ditches should be

directed under the road and through culverts placed on stable slopes, not at the end of roads or switchbacks. Culverts should be installed at an angle of fifteen to thirty degrees toward the inflow of the ditch and have a minimum one percent slope. Rock armor, drop inlets with boxes or filters, and catch basins installed at the culvert inlet will reduce plugging. Culverts should be installed along the natural slope under the fill in areas with high flows, high fills, or erosive slopes. Rocks or other energy-dissipating materials must be placed below the culvert outlet to prevent gully erosion.



Figure 3.31: Flexible plastic culverts are attached to the ends of metal culverts conveying water collected on the road over the fill slopes. Bear Canyon Mine.

Crowned road surfaces are used in flat terrain and on wide roads, such as haul roads. The crowned surface allows the water to quickly drain to each side of the road. Water that is collected from crowned road surfaces must be carried away from the roadside with ditches and culverts.

Seed, cut and fill slopes the first possible planting season after the final grade is achieved. Use a temporary seed mixture or mulch until a permanent seeding can be established. When slope stability allows (up to 1 ½ h: 1 v), the cut and fill slopes should be ripped, topsoiled, roughened, and seeded. Many seeding failures on cut slopes are from lack of topsoil and compaction. Do not seed plants along roads that are known to provide food and cover for large wildlife species.

Road Maintenance

Dirt roads should be graded only as needed and only those sections requiring maintenance should receive attention. Also, clean ditches as needed. The toe of cut slopes or pulling ditches should not be cut during grading. Excess material from grading should be hauled away and not side-cast. Designed in-slopes or out-slopes should be retained during grading. Berms or depressions that channel water down the road should not be left behind after grading. Water, gravel, or other treatments can be used on the road to avoid excessive dust.

Culverts should be marked with large painted stakes, so they can easily be located for regular maintenance. Periodically inspect and maintain culverts. Inspect culverts after rain or snow melt.

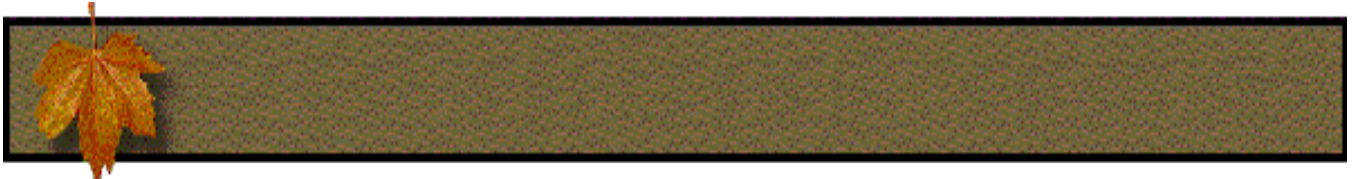

Chapter

4

Revegetating Disturbance

- **Revegetation Plan**
- **Application**
- **Success Techniques**

Revegetation Plan

Before disturbing any site, it is important to consider its potential for successful revegetation. If the site has gentle slopes and reasonably good soil, the following standard practices lead to successful revegetation.

Revegetation Success

Moisture is probably the most critical element for revegetation success. Revegetation of disturbed areas with annual precipitation levels lower than eight to ten inches depends heavily on the rainfall received the first two years after seeding. Seeding in these areas of low rainfall is problematic and may require several reseeding attempts, depending on weather patterns in any given year. Seeding in areas that receive more than ten inches of annual precipitation is generally successful if the minimum revegetation standards are followed properly. The procedures and revegetation techniques described in this section are those that have proven to work in most situations.

Seed selection is based on the post-disturbance land use and the desired vegetation cover. Landform and revegetation will depend on the post-disturbance land uses, such as:

- Residential
- Livestock grazing
- Wildlife
- Conservation and restoration
- Industrial
- Recreational

Evaluating Site Potential

Reclamation and revegetation costs increase in harsh environments or in environmentally sensitive areas.

Harsh environments consist of:

- Steep slopes
- Poor soils
- Extremely windy sites
- Extreme low rainfall
- High noxious weed potential
- High elevation

Environmentally-sensitive areas consist of:

- Critical wildlife or plant habitat
- Proximity to perennial streams or water sources
- High visibility areas

Harsh and sensitive sites should be avoided when possible. Suggestions include re-routing access roads or moving the drill pad to avoid the seep area. When avoidance is not possible, the sites will require special practices and techniques.

Planning to Revegetate

Planning is a crucial element when seeding. The final seeding plan should be developed at least one year prior to the actual seeding or planting date and the seed and planting material ordered as far in advance as possible. Knowing the size of the area to be seeded is essential for ordering the correct amounts of materials.

Note: A longer lead-time may be required if custom-grown plant material is used or if a specific site requires special collections of seed.

What to Plant

To determine what to plant, develop a list of seed species based on the proposed post-mining land use and the site characteristics, such as soils, precipitation, elevation, temperature, and vegetation in surrounding areas. Most mine areas in Utah are considered unimproved rangeland. If native plant species of the site are selected, they should adapt to the climate, soils, and elevation of the site. However, because of high cost and altered physical conditions, such as soils and topography, it is not always practical or possible to duplicate the surrounding community. When developing a seeding or planting species list, include several alternate species to allow for substitutions if the cost proves to be prohibitive or if the seed is unavailable.

Seed mixtures should contain several species of each life form. Life forms for seed mixtures are generally grouped into three categories: grasses, forbs, and trees and shrubs. A typical seed mixture should have four or more species from each life form. Life forms for the seed mixture may be broken down further to describe the species as warm or cool season grasses, forbs, and shrubs.

How Much Seed to Plant

Base seeding rates on the number of seeds per unit area (the number of seeds per ft²) rather than weight per unit area (pounds per acre). Seeds of different species have different weights, so seeding rates based on weight per unit area will over-emphasize small-seeded species and under-emphasize large-seeded species.

Promoting Plant Diversity

A diversity of desirable native plants will establish more quickly on the disturbance if aggressive erosion-control grasses are not seeded. This includes rabbitbrush, alfalfa, yellow sweetclover, forage kochia, and some wheatgrass and brome cultivars developed for seedling vigor, emergence, or stand establishment. Seeding of aggressive species should be limited to areas at high risk for revegetation failure or erosion. The revegetation plan should at least allow for islands of diversity within the disturbed area to be seeded. Planting should consist of non-aggressive shrubs, forbs and /or grass species. Fertilizer should rarely be used within these islands of diversity.

Small or long, linear disturbances, such as roads or pipelines, can revegetate naturally without seeding if good topsoil handling techniques are practiced ([Chapter 3, Section 2](#)). This is beneficial because it reduces cost and promotes establishment of a native vegetation community similar to the surrounding area. Limitations to this approach are areas that are susceptible to:

- Invasions of noxious or pervasive weeds
- Sedimentation to streams or rivers
- Rill and gully erosion

Diversity in soils, slopes, and aspects will create diversity in plant communities. Do not blend all the salvaged soils into one soil. Instead, keep the rocky soils for slopes and deep loams for bottomlands. Recreate a steep rocky talus slope and watch the penstemons and asters establish.

The Forest Service, Bureau of Land Management (BLM), and the Division of Oil Gas and Mining (DOG M) are signors of the *Federal Native Plant Conservation Memorandum of Understanding* (www.nps.gov/plants), which promotes the use of native species in all plantings. Federal research agencies within the Intermountain region have been working to help get more native plant species into commercial production. Species that were unavailable several years ago are now in good supply.

The seed mixtures developed for highly erosive or intensively managed areas, such as livestock grazing, will need to contain more aggressive sod-forming grasses and fewer forb and shrub species. Aggressive sod-forming grasses generally consist of the introduced, with some native wheatgrasses and bromes. Land grant universities and NRCS Plant Materials' Centers have done much work to improve seed germination, seedling vigor, cold or drought tolerance, sod-forming traits in these grasses and in other species, seed production and forage. Legumes or forbs from the pea family like alfalfa are recommended additions to these aggressive types of grass seed mixtures. Legumes, in association with bacteria, will fix atmospheric nitrogen and make it available to surrounding grasses.

Note: Seed catalogues usually show the number of seeds per pound to allow for conversion from pounds per acre to number of seeds per square foot.

The Natural Resources Conservation Service (NRCS) (Thornburg 1982) recommends a broadcast seeding rate of at least forty pure live seeds per square foot. Others (*Horton, 1989*) recommend rates of fifty to one hundred seeds per square foot when seeding for erosion control. Seeding rates may need to be adjusted for factors such as climate, expected emergence, competitive ability of each species, and pressure from granivores, or seed-eating animals. The general rule is to reduce the seeding rate by one half when drill seeding.

Seed Ordering

When ordering seed, buy seed from reputable vendors. Do not base the selection of a vendor entirely on cost. It is important to consider the quality and source of the seeds. To supply seed that is adapted to a specific site, provide the seed vendor with the following:

- The location and elevation of planting area
- The request for all seed on a pure live-seed basis
- The need for certified or source-identified seed when possible

Then, require the vendor to provide the following information:

- Viability test
- Purity analysis
- Test date
- Crop and weed seed contaminants
- Seed origin and elevation

Quality seed pays off in better establishment, with absence of noxious and troublesome weeds. When ordering, allow sufficient time for response, mixing and delivery. However, plan twelve to eighteen months in advance for source identified seed.

Seed Quality

When the seed arrives:

1. Check the label.
2. Have the seed tested to verify the label is correct, especially if you have any questions about the seeds quality or vendor, or if the seed is very expensive. Go online to <http://www.ag.state.ut.us/divisns/planting/seedweed.htm> for more information about seed testing.
3. Call a Department of Agriculture inspector. Have the inspector take the sample for testing so there is no question about bias.
4. Retain a small sample for yourself.

Seed Label

Note: All seed sold in Utah must have an analysis label.

Elements of the seed label:

Germination (viability) Test makes sure the seed will sprout. For shrubs and forb seed, the viability test should be done within nine months prior to use. Allow eighteen months prior to use for grasses and alfalfa. The test age is critical for some species that lose viability fairly quickly, such as sagebrush, forage kochia, rabbitbrush, and others. Viability tests may be done in one of two ways:

1. A percentage of germinating seeds
2. A chemical (TZ or tetrazolium) test for products of metabolism.

These tests should also indicate the percentage of dormant seed. In legumes, dormant seed is normally listed as "hard seed" meaning seed that did not imbibe water during the germination test. Hard seed is considered viable.

Purity Analysis lists the percentage of pure seed, other crop seed, weed seed, and inert matter, such as leaves and sticks. The percentage of pure seed is not usually critical except as it relates to pure live seed or how seed will pass through the seeding drill. Some seed, such as sagebrush and forage kochia, maintains more constant moisture content and is protected by chaff. Therefore, it stores better if the percentage of pure seed is lower.

Look at the percentage of weed and other crop seed because there may be significant contamination. By Utah state law, the percentage of weed seed cannot exceed 0.5% for most weeds and 3.0% for weedy bromes. Most other states have similar laws. No prohibited noxious weeds are allowed. According to Utah law, the presence of restricted noxious weeds, which are dodder, wild oats, jointed goatgrass, poverty weed, and halogeton, must be shown on the label, and there may not be more than twenty-seven seeds per pound of restricted weeds.

Seed Origin must show label the state or country of origin. Many species are widely distributed, but the plants from one area may have many different adaptation characteristics compared to those in another. While fourwing saltbush is found in both Montana and New Mexico, plants from New Mexico seeds may not survive in Montana. They may germinate and survive for a few years, but a cold winter or other extremes may kill them.

In order to get seeds similar to the area being reclaimed, try to obtain seed from as close to the area as possible. A general rule is to use seed from no more than 100 miles away and 1000 feet elevation difference compared to the area being seeded. Doing this will probably require giving the seed dealer at least several months, possibly a year, of advance notice. However, some dealers have seed from a variety of locations and may be able to make a close match without advance notice.

Note: PLS or Pure live seed is the proportion of pure seed times the total germination (including dormant seed) percentage. For example, if the germination is 80% and pure seed is 95%, the pure live seed is 76%. This means that a 50 lb. bag of this seed would have 38 lbs. of pure live seed.

Certified Seed

Certified seed is high-quality, noxious weed-free seed with known genetic source identity and seed origin, high genetic purity, minimal amounts of other crop seed, weed seed, or inert matter, and a known presence or absence of certain seed-born diseases. Seed certification is an international program for quality and genetic identity assurance and is overseen in Utah by the Utah Crop Improvement Association. Only seed produced in accordance with the high standards of an official seed certification agency can be represented as certified.

Note: Seed that has an analysis tag or is accompanied with a seed analysis test is not necessarily certified. Certified seed of released varieties must have a blue (certified), purple (registered), or white (foundation or white (foundation or breeder) tag. These tags assure the buyer that high-quality seed is truly the claimed variety.

In addition to these categories for released varieties, there are three classes established primarily for unreleased germplasm accessions of native species. These are Source Identified (yellow tag), Selected Class (green tag), and Tested Class (blue tag). The most common of these is Source Identified seed. This is seed collected from natural stands or produced in seed fields where there has been no selection or testing of the parent material. However, buying Source Identified seed may assure the buyer of the seed origin and will give a much better idea whether the seed is adapted to the site where it will be planted.

Seed Labels

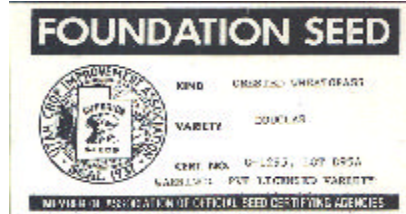
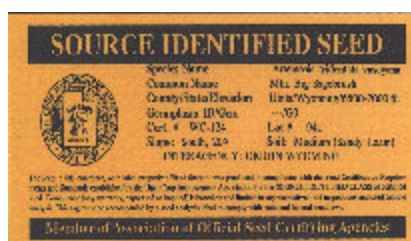

Seed Storage

Keep seed in a cool, dry place, and away from insects and rodents. Use mouse traps and bait if necessary. Nothing kills seed faster than storage at high temperatures and high humidity. While refrigeration at about 40° F may be ideal if containers are sealed so the seed remains dry, room temperature works reasonably well. If the seed has been stored for extended periods or in questionable conditions, have it tested prior to use.

Note: Seed life is generally doubled for every decline in air temperature of ten degrees. The numerical sum of air temperature and relative humidity should not exceed 100.

Application

The Best Time to Seed

Fall seeding is recommended for cool season species in Utah. Seeding is most successful when done just before the beginning of the season receiving the most dependable precipitation. Fall seedings should be made late so germination will not occur until the following spring, generally after October 1st at mid elevation sites. Early fall seedings are very risky since adequate root establishment may not occur prior to heavy frost and winter conditions. During winter, exposed seedlings can experience high mortality rates, especially in areas of limited snow cover (Horton, 1989). Seeding can be done in the winter if the soil surface is not frozen and is loose and friable. Some seed has a chilling requirement and needs seeding three to four months in advance of germination.

Warm season species are seeded just prior to dependable summer rains, usually June 1 - August 1. Warm season species are plants that have adapted to extremes of light, temperature, and drought and generally require warm soil to germinate and grow. They are found in Utah in the arid and semi-arid areas of the state. Warm season species are dependent on warm summer rains that originate from southern storms or hurricanes, referred to as monsoons. Seed catalogues usually describe grasses as cool or warm season. Examples of warm season species found in Utah are buffalo grass, galleta grass, blue gramma grass, and sand dropseed. Two planting times are required when seeding both warm and cool season species. If only one seeding can be done, seed the cool season and warm season together in early summer. Seeding warm season grasses in the late fall has had limited success in Utah.

Preparing The Site

Seedbed preparation or cultivation practices break and loosen the soil surface to allow any surface water to be captured. Seedbed preparation also provides protected micro-environments, causing better seed germination and growth. DOGM recommends extreme surface roughening as the best method of seedbed preparation for most range land situations. Complete the seeding right after roughening, before loosened soil has had a chance to crust, otherwise, the advantage is lost and raking will be necessary.

Note: See [Chapter 3, Section 2](#) for complete discussion on seedbed preparation techniques.

Seeding Methods

Seed is planted either by drilling or broadcasting. Some seeds, such as sagebrush and bluegrasses, need light to germinate and should be broadcast on the surface. Others, like Indian Ricegrass, require a deeper planting depth. A combination of methods can be used in some situations.

Note: Seeds should usually be planted at a depth equal to twice their width. This will vary with the specific species planted.

Use Table 4.1 to decide the best method of seeding for your situation.

Table 4.1 Seed application methods for Utah.

Situation	Drill Seeding	Broadcast	Hydroseeding	Aerial
Pasture	X		X	
Trashy, fluffy, or very small seed		X	X	X
Uniform seed size	X	X	X	X
Cliffs or very steep (1 1/2h : 1v)			X	X
Rocky soils or slopes		X	X	X
Small areas (10 acres)		X	X	
Large areas (50 acres)	X	X	X	X

Drill Seeding

Drill seeding places the seed in the soil at a prescribed depth. A drill is generally pulled behind a farm tractor or dozer.

The drill should be equipped with:

- Depth bands and press wheels
- Multiple boxes with agitators to prevent the seed from lodging in the seed box
- Chains attached behind the seed shoot to ensure even coverage of seed

The rangeland drill has been used by the BLM for decades to seed in rough, rocky terrain. Hybrid drill seeders are now available which incorporate several drill boxes for seeding different size seed on rough terrain. Drill equipment can be equipped with a cyclone seeder to broadcast seed that should not be drilled.

The drawbacks to drill seeding are that it:

- Reduces surface roughness
- Produces straight lines of plants
- Favors those species selected for drill seeding, such as wheatgrasses

Broadcast Seeding

Broadcast seeding is recommended for most situations, since it allows soil roughness to be maintained. Broadcast seeding places the seed on the soil surface. If the seedbed is loose and extreme roughening techniques are used, the seed is generally buried at variable depths due to sloughing. If the seedbed is crusted, then light raking to incorporate seed into the soil surface is required regardless of the broadcasting techniques used, including hydroseeding. Seeding immediately after extreme roughening will get the seed in the ground prior to surface crusting. Most seeds should not be left on the soil surface, because they can dry out or be eaten by wildlife.



Figure 4.1: On roughened soils hand broadcasting seed maybe the only option. Crawford Mountain Phosphate Mines.

Broadcast seeding is done with a hand held or equipment mounted cyclone (whirl bird) type seeder. Hand broadcast seeding is cost effective for areas as large as 25 acres. Areas larger than 25 acres are effectively seeded with large cyclone type seeders mounted on tracked or wheeled equipment or helicopters. The seed order may specify that trashy and fluffy seeds are bagged separately

trashy:
*contains stick,
leaves or chaff.*

since this seed will not flow through the hand held cyclone seeder. This trashy seed can then be applied by throwing the seed by hand in a systematic pattern.

Hydroseeding is a form of broadcast seeding which uses water as a carrier to apply the seed. Wood fiber hydromulch is added to the slurry at the rate of 100 to 300 pounds per 1500 gallons of water to reduce foaming and as a visual aid to the applicator. Seed and fertilizer should never be mixed in the slurry together since the salts in the fertilizer can reduce seed germination by as much as fifty percent. The seed should be added to the water slurry immediately prior to seeding, since seed should not be in the water for longer than thirty minutes. If left longer, it softens or even starts to germinate and can be damaged when being applied.

Calibration Methods

There are several calibration methods. One of the most practical measurement methods is to select a small area of a known size (example: 1/8 to 1/4 acre) to be seeded. A measured amount of seed for that size area is applied. The applied amount of seed is compared to the specified rate.

The applied number of seeds per square area (broadcast) or per liner foot (drill seed) are counted and compared to the specified rate of application (number of seeds/unit area). This method is not as accurate as others since small or dark seeds are difficult to see on the soil surface.

Lay several square foot pieces of paper on the ground prior to hydroseeding or aerial seeding and then count the seed after the application.

Drop tubes on drill seeders are covered with plastic bags, the measured area passed over by the drill, collect the seed from the bags and weigh the seed. Drill seeding small areas will over apply the seed because of overlap and turning.

Continue adjusting the amount of seed until the correct seeding rate is obtained. Once the correct rate is obtained, one only needs to spot-check application rates.

Note: The ground measured surface area can be different from area measurement obtained from maps. This difference is due to larger area on a slope than shown on a topographic map and surface undulations. The difference between the measured maps and on ground surface can be as large as fifteen percent.

Irrigation

Irrigation to establish native vegetation on reclaimed sites has generally not been used in Utah except in test plots where it has shown some promise for increasing plant establishment. Irrigation is routinely used to enhance germination and establishment on sites in New Mexico and Nevada. Irrigation has potential for use in Utah for areas with annual precipitation below ten inches.

Note: Native plantings should only be irrigated at a rate that would mimic a wet spring and only for the first establishment year.

Revegetate With Live Plants

Transplants

Transplants are most often used to establish shrub or tree species, but plugs of grass or grasslike species have been used successfully in very dry areas, for wetland plantings, and to get quick establishment. Transplants are



Figure 4.3: Pack the soil firmly around the seedling. Grizzly Gulch Mine Dumps.

available at nurseries which specialize in native species or conservation plantings.

Because of the higher costs of transplanting, usually only those species that are difficult to establish from seed are transplanted. Nursery

transplants are container- grown or bareroot stock. Cuttings, sod, and front-end loader transplants from an adjacent undisturbed area have also been used in revegetation efforts. Bitterroot Restoration, Inc., includes the following modified planting instructions with all containerized plant material. The same general instructions can be used for bareroot plants also.



Figure 4.2: The top of the plant roots should be covered with no more than 1/2" of soil. Grizzly Gulch Mine Dumps.

Transplanting Instructions

Delivery and Storage

- Store transplants in a cold area between 30 and 35 °F
- Check plants daily after delivery
- Keep moist until planting
- Open all shipment boxes
- Inspect plants for moisture status upon arrival

Planting

- Plant seedlings as soon as possible after delivery.
- Prepare ground by removing all vegetation within a twelve-inch square area (or more), to bare mineral soil.
- Planting sites can also be sprayed with Roundup or other herbicide (read herbicide label).
- Remove competing vegetation one or more days prior to planting. Bitterroot recommends that all upland plants are in a dormant condition when planting and a spring or fall planting is suggested. The plants should not have any green showing on the buds if in a dormant condition.
- Make sure the planting hole is an adequate size (a few inches deeper than the seedling roots) using an implement such as a tree planting spade, auger, planting bar, dibble, or shovel.
 - Note: It is important to avoid compacting the sides of the hole, because this can inhibit root growth into the surrounding soil. Bars or dibbles are not recommended for clay soils due to this potential compaction.*
- Remove seedling from the container by gently pulling at the base of the stem. Do not tear roots as you pull the plant from the container.
- Do not remove the plant from the container (bareroot stock should be kept moist in burlap) until the hole is ready for planting.
- Place seedling in the hole, make sure the plant is upright. Roots should not be tangled or bent upwards. Pack the soil firmly around the seedling, but do not compact the soil. The rooting media or top of the root ball should be covered with ½ inch of soil.
 - Note: Leaving the plants with the nursery soil exposed will cause dehydration and kill the plants.*
- Water seedlings immediately after planting, and again during midsummer of the first growing season. Arid areas of the state (less than 10 inches annual precipitation) will require more watering the first year. Apply a minimum of one liter of water to the dug hole prior to and one liter after placement of the plant. Apply additional water at two to four week intervals throughout drier portions of the year.
 - Note: In areas with extreme environmental conditions and/or animal browsing transplant protection may be necessary to ensure survival. Chicken wire is used to prevent browsing however, it must be removed after establishment. Several studies in arid areas have shown that plastic cones (Tree-Pee, Baileys Inc., Laytonville, CA and Tubex, www.tubex.com) or tubing greatly improve transplant survival rate while other studies show no increase in survival.*

Success Techniques

Inoculation with Microorganisms

Legumes, such as alfalfa and northern sweetvetch should be inoculated with the proper *Rhizobium* bacteria. In a mutualistic relationship with legumes, *Rhizobia* transforms atmospheric nitrogen into a form that can be used by plants. These bacteria are often present in native soils, but when soils are stockpiled or another growth medium is used instead of topsoil, these bacteria are absent. Seed suppliers usually have the *Rhizobium* inoculum and can inoculate the seed. When ordering legume seed, you must specify that it be inoculated.

Mycorrhizae are fungi that form a mutualistic association with plants, enhancing the growth and development of both. Mycorrhizal fungi help the plant by increasing the plant's effective root volume as much as eighty times, improving potential water and nutrient extraction from the soil. Mycorrhizae spores are distributed by wind and most reclaimed sites are inoculated naturally within a year. Commercial sources of mycorrhizal inocula are available, especially for conifers. The most commonly available commercial mycorrhiza is *Pisolithus tinctorius*, an ectomycorrhizal species for conifers. When reclaiming small sites or islands within larger sites, inoculum can be collected locally by gathering soil and fine roots from healthy plants in nearby nutrient-poor areas. Commercial or local inoculum needs to be placed in the root zone of actively growing plants at approximately one to three-inch depths. Mycorrhizae species are host-specific and a generic inoculum may not be effective for a specific plant species. Several nurseries grow mycorrhizal plants for out-planting or contract to grow plants using soil from undisturbed areas that contain spores. Carrier plants should be planted on five-foot centers. Fertilization is not recommended, since nitrogen and phosphorus in the soil decrease the rate of infection.

Some sources of mycorrhizae:

- Bitterroot Restoration (406)961-4991, <http://www.revegetation.com>, (plants)
- Reforestation Technologies International, (800)784-4769, <http://www.reforest.com>
- RootsInc, (800)342-6173, <http://www.rootsinc.com>
- AgBio, (303)469-9221

Weed Prevention

Follow these steps in order to limit or prevent the number of problems weeds create for reclamation:

- Do not use fertilizer. When a soil test indicates the need for fertilizer, limit the amount, especially of nitrogen. Most native plants use limited amounts of nutrients, while weeds grow quickly and used large amounts. Many times, fertilizer benefits the weeds more than the plants.
- Control noxious weeds during operational phases to limit the amount of seed in the soil.
- Obtain borrow soil or fill from an area free of noxious weeds.
- Control weeds on the topsoil stockpile by planting these storage areas with preferred species.
- Use quality materials. If using straw or hay for mulch, use certified noxious weed free straw or hay. This is required on federal lands. Use certified seed where possible and buy all products from reputable dealers. Look at the seed label and see how many weeds are being imported with the seed. Utah law allows up to 3% of certain types of weeds, but you can often find seed with few or no weeds.
- Use clean equipment. Require contractors to clean their equipment before mobilizing.
- Do reclamation once and do it right the first time. Redisturbance makes an ideal situation for weeds to grow in great numbers, increasing costs.
- Plan grading and topsoiling operations for the fall so seeding can occur soon after topsoiling is completed. This way, the weeds do not get a head start.
- Use competitive species if you anticipate a problem. Seed species that are known to compete well with weeds in the reclaimed area. Examples include forage kochia in areas with severe cheatgrass infestations and some wheatgrasses with broadleaf weeds.

Weed Control

While weeds come into almost every reclaimed area, using the best revegetation techniques the first time will give desirable vegetation a much greater chance of establishment. It is not usually necessary to control common weeds like Russian thistle, kochia, lambsquarters, and pigweed if enough of the desired species are present. This amount varies between sites but is approximately a minimum of one seeded plant for every two square feet in middle elevation rangelands in Utah. Do not rush to reseed or redisturb an area that has a lot of weeds. This will often create a good seedbed for billions of weed seeds. Weeds are a normal part of reclamation, and control is often not necessary.



Figure 4.4: Musk thistle (a noxious weed) plant and seedling.

Weed Control

Consider all available control techniques, including: cultural, biological, herbicidal. This is commonly referred to as Integrated Pest Management (IPM).

1. Cultural methods include pulling weeds by hand, cultivation, and grazing.
2. Biological controls include using insects, animals, and diseases to control the weeds. These methods are used when managers hope to control the spread of a weed and limit its numbers and adverse effects rather than to eradicate it.
3. Herbicides are often the first thing considered when they should be the last. Always remember that herbicides are extremely toxic chemicals. The land owner should always be consulted prior to using chemicals. General concepts of herbicide usage:
 - Read and follow label directions. Failure to do so is a violation of federal law.
 - Be careful when mixing chemicals and rinsing equipment. This is when most spills happen and contamination of the environment occurs. Be especially careful to keep chemicals out of waterways.
 - Use the lowest application rates that will accomplish the purpose.
 - Use chemicals that are as selective as possible for the target weed.
 - Do not mix more spray than you need to do a job or that you will use in one day.
4. Prevention is the easiest and cheapest. Manage the land in good condition. A healthy plant community will usually exclude weeds.

Weed Management Strategy

If you decide there is a weed problem when consulting with the Utah State University (USU) Extension agent or other expert, use the following guidelines to plan a strategy. If you anticipate weeds will be a problem, begin as early as possible to develop a plan before reclamation.

- Prevention .
- Identify weed problems. Use identification manuals and weed experts, such as the USU Extension agent, state agriculture inspector, and officials of the NRCS
- Keep maps, records, and dates. Write down locations of infestations and how many weeds are encountered. Notify county weed control officials of anything out of the ordinary. Prioritize weeds. Some weeds are a bigger problem than others. Eliminate highly competitive, noxious (see lists below) weeds if possible, suppress those that are moderately competitive, and do not worry about others. Weeds are a normal part of reclamation, and control is often not necessary.
- List controls options, such as biological, chemical, landowner, or mechanical. Consider personal experience, local experts, and published information.
- Design a weed management program.

When designing a weed management program:

- Look at costs, management skills, and required equipment availability.
- Consider environmental aspects, including what vegetation might be damaged and whether ground or surface might be contaminated.

Weed control efforts must continue year-round. Most weed control is concentrated in the spring, but control techniques in the summer and fall may enhance effectiveness of work in the spring or may be the best time to control a particular species.

- Follow up. Tough weeds are rarely eliminated the first time around, and it is easy to miss a few plants. Most weeds have seed that can lie dormant for at least a few years, then germinate when conditions are right.
- Use the simplest methods available that will do the job. For example, do not use an aerial spray program if you can spend an hour digging out a few plants.

Utah Noxious Weed List

Bermudagrass** (*Cynodon dactylon*)
Canada thistle (*Cirsium arvense*)
Diffuse knapweed (*Centaurea diffusa*)
Dyers woad (*Isatis tinctoria*)
Field bindweed (Wild Morning Glory) (*Convolvulus arvensis*)
Hoary cress (*Cardaria draba*)
Johnsongrass (*Sorghum halepense*)
Leafy spurge (*Euphorbia esula*)
Medusahead (*Taeniatherum caput-medusae*)
Musk thistle (*Carduus nutans*)
Perennial pepperweed (*Lepidium latifolium*)
Perennial sorghum (*Sorghum halepense* & *Sorghum almum*)
Purple loosestrife (*Lythrum salicaria*)
Quackgrass (*Agropyron repens*)
Russian knapweed (*Centaurea repens*)
Scotch thistle (*Onopordum acanthium*)
Spotted knapweed (*Centaurea maculosa*)
Squarrose knapweed (*Centaurea squarrosa*)
Yellow starthistle (*Centaurea solstitialis*)

Updates to this list are found at www.ext.usu.edu/ag/weeds/index.htm.
Bermudagrass shall not be a noxious weed in Washington County and shall not be subject to provisions of the Utah Noxious Weed Act within the boundaries of the county. Several other weeds are listed as county noxious weed.

Weed Publications

Two excellent publications on weed control and weed identification are:

1. ***Montana Utah Wyoming Weed Control Handbook***, published by the extension services of Montana State University, Utah State University, and the University of Wyoming. This manual is updated periodically and focuses on the most recent information on herbicidal weed control. Some of the information in this section was taken from this handbook.
2. ***Weeds of the West***, published in 1991 by The Western Society of Weed Science and Western United States Land Grant Universities and Cooperative Extension Services. This book has excellent photographs and descriptions of weeds.

Grazing Protection

Protection of reseeded areas is essential to the success of the revegetation project. Transplants are very tasty to animals and are susceptible to rabbit, rodent, deer, and elk grazing. Rigid tube and cone-like plastic are available to place over transplants which can reduce grazing pressure. Seeded areas should be protected from unmanaged livestock grazing. Fencing is usually necessary to protect the seeding from trespass livestock. Any grazing within the first few years of establishment must be intensively managed. Newly seeded areas are sometimes briefly grazed to reduce weed growth, smooth rills, and stimulate grass production. The Utah Division of Wildlife Resources should be contacted if wildlife becomes a problem on the reclaimed site.

Reseeding or Seeding Failure

Revegetation efforts should not be considered a failure for a minimum of two years after original seeding in areas with greater than fifteen inches of precipitation. Drier areas may need three to five years before evaluating seeding success. Seeding is considered a failure when an average of less than one seeded species per square yard is established on all but the very driest sites. Observation of young seedlings may be difficult on weedy sites. Observe after frost or before spring germination for an unobstructed view of seeded plants. Reseed sooner rather than later in critical planting areas, such as those near water or noxious weeds, or when concerned with a pending bond release. Do not reseed the entire site if spot seeding or supplemental seeding will do the job. To help prevent future seeding failures, evaluate why the initial seeding failed by asking the following questions:

- Was the year drier than normal?
- Was the spring drier than normal?
- Was good seed used from a reputable vendor? Was the seed tested?
- Were the best adapted seed varieties, sources and species used?
- Was the area missed by the seeder?
- Was the seed eaten by rodents or birds?
- Was the seed exposed to wind or water erosion?
- Was the seed planted too late in the spring or too early in the fall?

Mulch

Mulch is generally used as an aid in erosion control and not necessarily seed establishment. Mulch or organic matter helps to reduce the amount of erosion caused by raindrops impact. Results of test plots and literature concerning the use of mulch to aid in seedling establishment in Utah are varied and contradictory. Mulch is more important as an erosion control method than for seedling establishment. The need for mulch should be based on erosion control needs rather than a standard prescription for revegetation seedings ([Part 2, Section 3](#)).

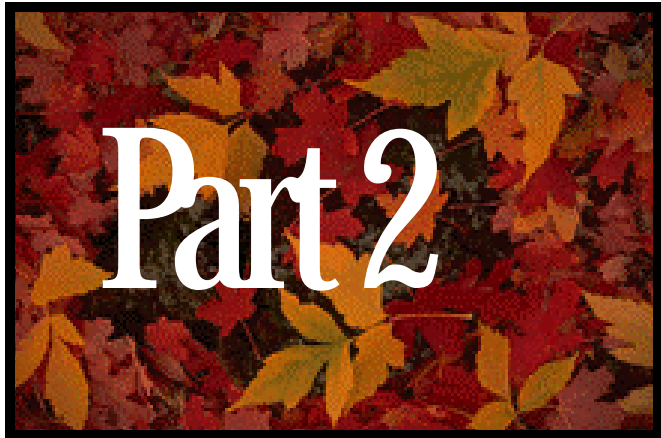

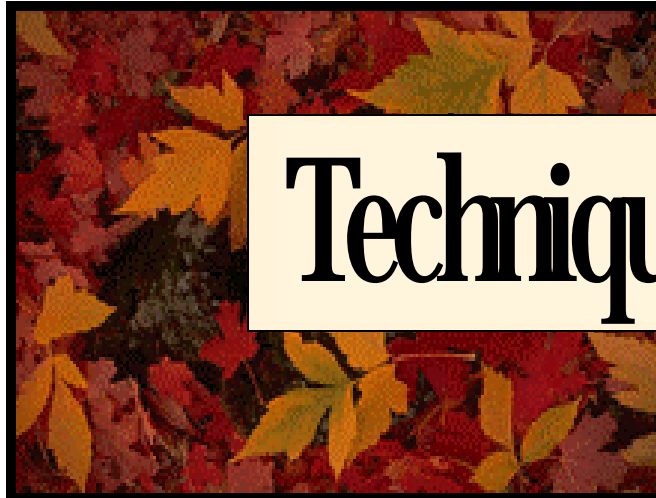

Technique Sheets

- Extreme Surface Roughening
- Vegetation
- Mulch
- Erosion Control Matting
- Slope Shape
- Vegetative Filter
- Straw Bale Barrier
- Silt Fence Barrier
- Temporary Diversions
- Temporary Slope Drain
- Outlet Protection
- Inlet Protection
- Check Dam
- Temporary Sediment Trap
- Sediment Ponds

Extreme Surface Roughening

Extreme surface roughening, which is also known as pocking or gouging, is used to intercept and trap sediment on a microscale. Roughening also collects moisture, which improves vegetation establishment and consequently

discontinuous ripping: *lifting ripper blades every ten to fifteen feet to prevent long water pathways.*

prevents erosion. Surface roughening is highly recommended for moderate to



Figure 1.1: Straw is incorporated into the soil when roughening the soil surface. Crawford Mountains Phosphate Mines.

steep slopes (up to 1h:1½v) but is also useful for flat or gently sloping areas with erosive soils and arid climates. Extreme surface roughening is most practical for use on small disturbed areas of fewer than fifty acres or for critical portions of large disturbances, such as highly erosive soils and areas adjacent to streams. Discontinuous ripping on the contour can be used to roughen larger disturbed areas.

Basic Design and Construction

Use a backhoe or trackhoe shovel to create microbasins for extreme surface roughening. The trackhoe shovel is used to dig, poke, or push basins with a minimum depth of eighteen inches. These basins should be 1 ½ to 2 feet deep and have the width of the bucket. This allows the basins to be up to four feet wide. The most common construction method is to dig a bucket load of soil and then drop it 2 to 3 feet above the soil surface. Repeat this process in a random and overlapping pattern, making it impossible for water to flow down slope. Finished roughened soils should be difficult to walk over. On poor, shaley sites, such as the Mancos Shale, the pocks can fill with sediment within a short time period.

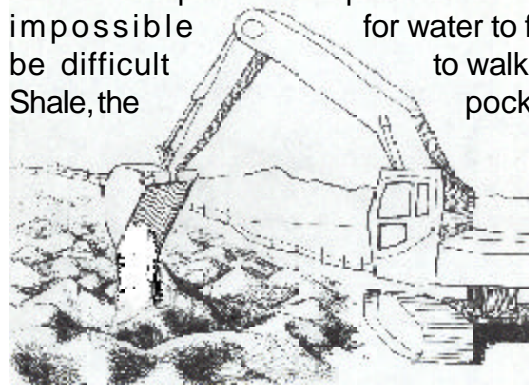

Figure 1.2: A trackhoe is used to create microbasins. Drawing by Jenny Suflita.

Therefore, the pocks should be as large as possible on these soils. Conversely, on-sites with adhesive soils, the pocks should not be too large, because they would not fill in with sediment over time. Straw, alfalfa, or hay can be spread during roughening and anchored to the soil surface by jacking the materials into the soil surface or tacking them with a hydromulch slurry.

Because a drill seeder cannot be used on such rough surfaces, seed must be broadcast (Chapter 4, Section 2). In areas with extremely dry and loose soil, it may be advantageous to wait until the soil has settled before starting the seeding process. One method is to broadcast half the seed immediately and broadcast half the seed after the soil settles.

Ripping is used as a soil roughening technique in areas too large to economically roughen with a backhoe. Ripping breaks up compacted layers of soil. Seed can be simultaneously spread with the ripping operation if a broadcast seeder is attached to the ripping equipment. Soil amendments or surface mulch are incorporated into the soil during the ripping operation or anchored with non-surface disturbing methods such as tackifier or netting. Rip soils when they are dry to permit shattering beneath the surface.

Ripping guidelines:

- Rip to a depth of 2 to 3 feet.
- Make rips contour to the slope.
- The distance between rippers should be equal to the depth ripped.
- Lift the ripper from the soil every 10 to 20 feet to reduce long water pathways.

Problems may occur if:

- Basins are made when the soil is wet, causing hard, compacted soils to form in the depressions when dry.
- There is too much space between basins. Basins need to be overlapping.
- Basins are not large enough, which causes them to fill in prior to vegetation establishment.
- Basins are used as a permanent erosion control method when they are only temporary (2 to 3 years) in areas of low vegetation cover.
- Ripping resembles contour furrows, which can concentrate water and cause catastrophic breaching.

Vegetation

Establish vegetative cover on exposed soils. This provides protection from sheet and rill erosion. Seeding can be used as an interim, long term, or permanent erosion-control solution.



Figure 2.1: The vegetative cover on this reclaimed mine is controlling erosion. Horse Canyon Mine.

Interim seeding is used to stabilize soil exposed from four weeks to one year. Interim seeding consists of seeding annual grains, which provide quick cover and then die off, adding organic matter to the soil. Rapid growing perennial grasses are used to stabilize areas that will remain unused for more than one year and on operational areas that will not be disturbed for the life of the project. This includes cut or fill slopes, roadsides, topsoil piles, sediment pond embankments, diversions, and other operational areas.

A diverse mixture of grasses, forbs and shrubs are used for permanent soil stabilization on reclaimed sites. When the desired temporary or permanent seed mixture cannot be applied because of the season, an interim seed mixture suitable for the current season is seeded. The interim planting is either left as stubble or mixed into the soil surface when the correct seeding window arrives.

Basic Design and Construction Criteria

Each area to be seeded should be ripped, loosened, and roughened prior to seeding. This operation should be performed only when the soil is in a tillable and workable condition. The soil should not be too wet or extremely dry.

The seed mixture guide is recommended only for temporary plantings. These seed mixtures are not designed for specific sites and lack the diversity required for a final seed mixture in a permanent reclamation situation ([Chapter 4, Section 1](#)). Consult with the local County Agricultural Extension Agent for additional recommendations.

Ideally, interim seedings should use grain species that will not produce seed during the current season. Sterile grass seed such as Regreen may be seeded at a rate of 40 PLS pounds per acre.

Temporary Seed Mixtures for Typical Sites in Utah

The seed vendor must furnish a certified laboratory report from an accredited commercial seed laboratory, signed by a Registered Member of the Society of Commercial Seed Technologists, or from a state seed laboratory showing the analysis of the seed to be purchased. Taking samples of the seed to check against the certified laboratory report ensures that the seed was indeed the species ordered.

Temporary Seed Mixtures

This temporary seed selection guide is provided for erosion control in areas that will be disturbed prior to final reclamation. These seed mixtures contain aggressive, non-native grasses and are not suitable for establishing a permanent and diverse vegetative community.

Semi-Arid Sites - < 14" rainfall

- Crested wheatgrass
- Bluebunch wheatgrass
- Intermediate wheatgrass
- Pubescent wheatgrass
- Thickspike wheatgrass
- Palmer penstemon

Upland - 14" to 22" rainfall

- Smooth brome
- Paiute orchardgrass
- Intermediate wheatgrass
- Pubescent wheatgrass
- Crested wheatgrass
- Western wheatgrass
- Thickspike wheatgrass
- Alfalfa

Mountain - > 22" rainfall

- Kentucky bluegrass
- Timothy
- Smooth brome
- Mountain brome
- Slender wheatgrass
- Intermediate wheatgrass
- Orchardgrass
- Alfalfa

Seed should be broadcast at the rate of 50 to 100 seeds per square foot, or 15 to 25 PLS pounds per acre. Interagency Forage and Conservation Planting Guide for Utah, 1989, provides seed mixtures for specific regions and soil types in Utah. Check with the land management agency, such as the Bureau of Land Management (BLM) or Forest Service, for preferences.

Mulch

Certified, weed-free mulch should be applied after fall seeding for winter cover and on all slopes that exceed 3H:1V.

Problems may occur if:

- Seeding is done at the wrong time when the soil is too dry for adequate germination.
- Annual, non-sterile crops are used for temporary seeding. These can reseed themselves and make it difficult to establish a good cover of permanent vegetation.
- Seeds are not broadcast evenly or the application rate is too low. Both conditions result in patchy growth.

- Seedbed is not prepared properly. This could include soil that is too compacted or has not been adequately roughened for water catchment.
- Plant materials are unsuitable for the area.
- Noxious weeds are brought onto site during construction or from straw or hay bales.

Note: Certified, weed-free straw and hay can be ordered ([Chapter 4, Section 3](#)).

Maintenance

Frequently inspect during the first six weeks of the planting or growing season to see if germination is uniform. Operational areas may make provisions to water as needed to penetrate to a depth of six inches. Check for damage that could be caused by equipment or heavy rains. Damaged areas should be repaired, seeded, and mulched. Tack or tie down mulch as necessary. Inspect for noxious weeds and plan for control program ([Chapter 4, Section 3](#)).

Mulch

Mulching means covering a disturbed soil surface with plant residue or other suitable material, such as rock, for the purpose of stabilizing the soil surface, slowing erosion, and preserving soil moisture. This is an immediate, effective, and economical erosion-control practice, although it is not permanent unless the material is rock. Mulching with organic material is generally suitable for one to two years.

Mulch is used to reduce raindrop impact, water runoff, or wind erosion. In addition to this, mulch may aid in soil water infiltration and to hold seed in place. Bare soils can be protected by mulch until vegetation is established. Mulches are most suitable for flat or gently sloping areas, but may be anchored to steep slope areas by means of nets, mats, or tackifiers.

Basic Design and Construction Criteria

Material Selection

The selection of mulching materials will depend primarily on site conditions and availability. Organic mulches such as straw, hay, wood fiber, organic debris, wood chips, or inorganic rock are usually preferred because they are effective and compatible with the environment.

Rock

Rock is used on arid site reclamation as a permanent mulch to stabilize the soil surface and reduce evaporation in areas with less than 40% vegetative cover. The use of rock as surface mulch is an attempt to copy the desert pavement, or rock veneer found occurring naturally in Utah deserts. Armoring soil with rock riprap or thick gravel mulch is a common practice on radioactive waste burial sites in arid environments. This rock armoring breaks up raindrop energy, reduces flow velocity, and increases water movement into the soil. Rock mulch consisting of various sizes of gravel (1/10 to 3 inches) is more effective in reducing sediment loss from overland flow or wind erosion than cobbles (>3 inches) (Waugh 1994). Large-sized cobbles, rocks, and boulders provide shading, trap wind-blown snow, and help create microclimates within reclaimed sites. It is



Figure 3.1: Desert pavement armors the soil surface and controls erosion in Utah's arid deserts. Emery County.

recommended that rock used as mulch consist of interlocking angular shapes, ranging in size from small gravel to large boulders.

Rock mulch can either be applied as a surface layer treatment or mixed with existing surface soils. Rock or rocky soils can be salvaged during operations and stockpiled for reclamation use. Optimum rock coverage means that 60% to 70% of the

soil is covered with rock after rain has washed the surface fines. This type of coverage has been equated to two tons per acre of straw (Harper 1982). Reasonable rates of application are one to two inches of rock material mixed into the top six inches of soil. Rock materials for use in reclamation can be salvaged or mined at the site or obtained from sources such as the Utah Department of Transportation (UDOT) gravel reject piles and commercial gravel sources.

The Dog Valley Mine (J. B. King Mine) and Hidden Valley Mine in Emery County have both used rock mulch. The rock mulch has been more effective in controlling erosion than previous use of straw and erosion control matting.



Figure 3.2: A roughened surface and slash mulch laid across this reclaimed exploration road prevents off-road vehicle access. Deer Creek Mine Exploration.

Slash mulch is limited to those operations that can use the salvaged plant material immediately, or have space to stockpile the material. Slash has been successfully used at Utah sites in reclaiming exploration drill pads and roads in forest areas.

Numerous logs laid perpendicular to roads acts as a deterrent to off-road vehicles and grazing cattle, while visually enhancing barren, reclaimed areas. Piles of slash left on the Horse Canyon Mine reclaimed site has made excellent burrows for rodents and snakes.

Straw, Grass Hay, and Alfalfa

Straw, grass hay and alfalfa must be obtained from fields that are certified by the Country Extension Agent as noxious weed-free. These materials are generally applied at

Slash

Slash refers to plant material salvaged prior to disturbance. These are dead shrubs, trees, brush, and tree and shrub parts. Revegetation work in Canyon Lands National Park has shown greater success with large mulch objects rather than straw or hay mulch (Belnap, unpublished) The large slash mulch helps reduce water and wind erosion, provides protection from large herbivores, and traps seed and fine soils on the reclaimed area. Unlike hay or straw mulches, slash does not introduce competitive weed seeds. Also, slash does not concentrate moisture at the soil surface, causing seeds to germinate when conditions are not favorable.



Figure 3.3: The large slash mulch will provide protection from cattle grazing. Deer Creek Mine Exploration.

the rate of one to two tons per acre, so that 80% to 90% of the ground is covered. Long fiber straw and hay are more desirable for surface erosion control than are shorter fibers. Hay or straw is spread after seeding, unless the mulch



Figure 3.4: Straw is hand carried and spread in rough terrain. Crawford Mountains Phosphate Mines.

material is incorporated into the soil surface during the surface roughening process. The straw, hay, or alfalfa mulch can be applied with a straw blower, tub grinder, or by hand. Surface applications of straw and hay will need to be anchored to prevent water or wind erosion. This can be done by:

tackifiers: *organic and inorganic chemical glue-like products that are applied in water solutions by hydromulcher.*

- Crimping or poking in a manner which leaves a stubble effect while enhancing surface roughness.
- Spraying with chemical tackifiers.
- Covering with netting.

Wood chips

Wood chips are available from lumber mills municipal dumps, or whole tree chipping from on-site trees (Chapter 3, Section 4). The decision to use wood chips as mulch or soil amendment will probably depend on the proximity of the wood chip source to the reclamation site. Wood chips decompose more slowly than hay, straw, or wood fibers and make a longer-lasting soil amendment or mulch. Chips have a high carbon (C) to nitrogen (N) ratio (615:1) making decomposition last from eight to fifteen years. Composting the wood chips with 20 pounds of nitrogen per ton of chips prior to application will moderately accelerate the decomposition.

wood chips: *pieces of wood that are 1/4" to 4" length and less than 3/8" thick.*

*Note: 5 pounds of Ammonium Sulfate = 1 lb. actual nitrogen
3 lbs. Of Ammonium Nitrate = 1 pound actual nitrogen
2 lbs. Of Urea = 1 lb. actual nitrogen
Ammonium Sulfate is 21% nitrogen
Ammonium Nitrate is 34% nitrogen
Urea is 46% nitrogen*

Wood chips are generally applied to a two-inch thickness as a soil amendment and 1/4" to 1" as mulch. A two-inch layer of wood chips will require approximately 270 cubic yards or thirty tons to cover one acre. Sawdust rapidly decomposes and demands a high level of nitrogen from the soil. Because of this high nitrification and rapid decomposition, sawdust it is not recommended.

Wood Fiber

Wood fiber is also known as hydromulch. Longer fiber wood provides greater erosion control protection than short fiber or paper pulp products. Hydromulch is dyed a green color as an aid in application, but soon fades to a light brown color. Wood fiber is mixed into a water slurry solution and sprayed on the soil surface at the rate of 1000 to 2000 pounds per acre. Tackifier, a plant-based glue, is added to the wood fiber mixture when it is applied to slopes. A small amount of wood fiber is added to a tackifier slurry solution for an overspray when used as a glue for hay and straw mulch.



Figure 3.5: A wood fiber mulch is sprayed on the soil surface with a hydromulcher. Gordon Creek 2, 7, & 8 Mines.

Netting

Netting is used to hold straw and hay mulch in place on steep slopes or in critical areas. Netting should be applied as stated in Erosion Control Matting ([Chapter 3, Section 4](#)).

Problems may occur if:

- Inadequate coverage results in erosion, washout, and poor plant establishment.
- Appropriate tacking agent is not applied or is applied in insufficient amount, leading to the loss of straw or hay mulch to wind and runoff.
- Netting is difficult to hold to surface on extremely roughened sites.
- Noxious or persistent weeds are brought in with hay or straw. Certified noxious weed-free straw and hay can be ordered. Inspect hay field prior to purchase or cutting.
- Too much grain seed in the mulch results in competitive exclusion of seeded species.
- Netting is stretched over soil contours, leading to erosion underneath. Netting should be loose enough to be in contact with mulch.
- Netting is too loose. This could allow the wind to catch under the netting, moving the mulch underneath.
- High application rates of mulch smother germinating seeds.
- Mulch keeps the soil too cool for seed germination during the wet, early spring period.
- Grass, alfalfa, straw and hay attract cows and wildlife, causing damage to the new seeding.

Maintenance

Inspect mulch after rainstorms or high winds to check for movement of mulch or erosion. If there is a washout, breakage, or erosion occurs, repair surface, reseed, re-mulch, and/or install new netting as necessary. Continue inspections until vegetation is established.

Erosion Control Matting

Jute mesh, excelsior matting, erosion-control fabric, or other matting is used to prevent erosion on previously shaped and seeded soils, soil-covered drainage channels and slopes, or other critical areas. The basic objective of erosion-control matting is to provide a stable seedbed for one or more growing seasons. Some are designed to last longer than others. Erosion-control matting disperses raindrop impact, then biodegrades and disappears as vegetation is established.



Figure 4.1: Excelsior matting is laid loosely over the seeded slopes. Bear Canyon Mine.

Basic Design and Construction Criteria

Erosion-control matting or blankets can be used on slopes steeper than 2½ horizontal to 1 vertical (2.5:1) or areas where maximum soil surface stabilization is desired, such as soils that are adjacent to waterways. Matting is laid parallel to the slope and staked down. Recommended installation will vary, depending on the product purchased. Some matting is anchored at the top of the slope in a trench that is 6" deep and 6" wide, while other products require no trenching. The matting should be laid loosely because it tends to shrink and stretch over high points.

In high wind areas and loose soils, the staples supplied by manufactures can easily come loose and the blanket can blow away. Surveying stakes can provide a stronger hold. Remove surveying stakes after the netting has deteriorated.

photodegradation:
the process of breaking down due to the effects of ultra violet sunlight.

Small-squared netting can trap and kill snakes. Snakes are beneficial on reclaimed areas because they control rodent populations. The photodegradation of the plastic in the netting can take up to ten years. Since netting can be detrimental to wildlife, reclamation projects should use netting with holes larger than 2" and a 2 year photodegradation life.

Site Preparation

Areas needing erosion-control matting should have been previously shaped and seeded. Except in drainages, the soil surface should be left in a very roughened condition.

Materials

Staples should be No. 11 gauge new steel wire, formed into a six to ten-inch long "U" shape. Use surveying stakes on loose, unstable soils. When selecting erosion-control matting, select fabric mats with a life expectancy equal to the length of time it will take for vegetation to establish and take over erosion-control.

Installation

Numerous erosion control mats currently exist. Erosion control products should always be installed in accordance with the manufacturer's instructions. The following list contains basic applications of erosion control mats:

1. Erosion control fabrics are especially useful for steep slopes. Erosion control fabrics may be applied perpendicular or horizontal to the slope contour lines, depending upon the slope length and width. However, they should always be placed in the direction of the water flow in ditch installations.
2. Prior to netting placement, an anchor trench (of no less than 6" deep and 6" wide) should be dug at the top and toe of the slope. The top trench should be placed one foot back from the slope crown, creating a berm over which the fabric can be placed and securely buried.
3. For horizontal application, the erosion-control fabric should be tucked into the top trench, stapled, and covered with topsoil. The material is then unrolled and stapled as the work proceeds. The strips should have a four-inch overlap and lay like house shingles. Enough netting should be in the trench at the bottom of the slope to secure it with staples and bury it with soil.
4. Over soils with extreme surface roughness, the netting should not be stretched, but allowed to lay loosely on the surface. Staples or rocks may need to be placed in the bottom of depressions so that the netting does not stretch over the pocks. When dealing with steep slopes, start at the bottom and roll uphill to prevent stretching.
5. Staple spacing is dictated by product, slope and soil conditions. See manufactures recommendation for staple spacing.
6. Where extremely erodible soil conditions are anticipated, a trench should be placed at the midpoint of the slope. The material should be stapled every 9 to 12 inches along the center of the trench, filled with topsoil, and tamped thoroughly.

tamped:
compact.

Problems may occur if:

- Areas are left uncovered or with inadequate coverage, resulting in erosion, washout, and poor plant establishment.
- There is inadequate anchoring at the top of the slope.
- An insufficient amount of staples are applied, the staples are not correctly spaced, or the surveying stake is not used in loose soil. These conditions may result in the netting being lost to wind and runoff.
- Deer hooves get caught in netting and pull the netting up.

- Netting does not photodegrade rapidly enough and snakes are caught in the small squares. To avoid this, use netting with large holes.
- There is failure to recognize area of water concentration along slope.

Maintenance

Inspect erosion-control mats after wind and rain storms to check for movement of matting, topsoil, mulch, or erosion. If there are washouts, breakage, or erosion, repair surface, reseed, re-mulch, replace topsoil, and install new netting. Continue inspections until vegetation is established.

Slope Shape

The size, shape, and slope of a reclaimed site will influence the runoff characteristics. Slope angle and slope length can be modified to reduce the water velocity or runoff period. Complex or concave slope shapes should be used on any slopes steeper than 5h:1v and/or with a length of greater than 15 feet. Erosivity of the soil will play a major factor in design.



Figure 5.1: Concave slopes reduce amount of fill material required to backfill the disturbance. Gordon Creek 2, 7, & 8 Mines.

Basic Design and Construction Criteria

Selection of Shape

To determine which landforms are most suitable for a reclaimed site, observe the landforms of undisturbed watershed areas that have similar soils and characteristics as the site. Long term mass stability requirements must be considered. Slope stability must be evaluated by a Geotechnical Engineer when large fills, tailings, or waste embankments are involved.

Convex slope shape is more erodible than a uniform slope because it is steepest near the toe. Concave slopes produce less sediment than either the convex or uniform slope because the concave slope is steepest where the flow is least and has a deposition zone near the bottom of the slope. Long slopes should be broken up with a series of varying lengths that create complex slopes. Concave or complex slopes provide a series of flat toe areas that serve as sediment deposition zones.

Flatter slopes will increase rainfall infiltration and decrease sedimentation. However, long moderate slopes are not always better. Reduce slope length by quickly increasing slope angle on sites with low vegetative cover, low soil permeability,

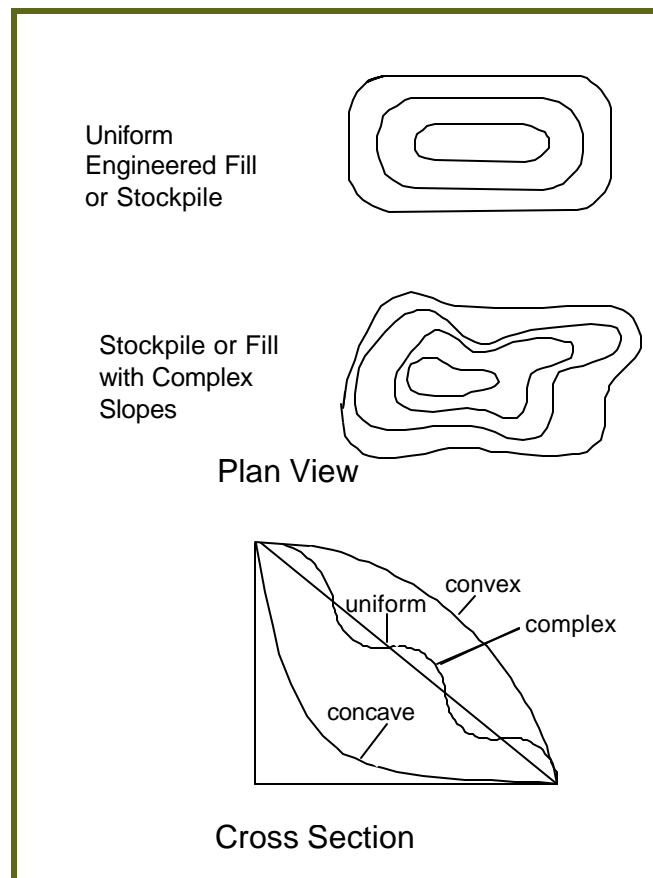

Figure 5.2: Slope shapes, complex slopes maximize sediment deposition zones. Adapted from Norman et. al 1996.

and highly erosive soils, such as very fine sands and silts. This will allow a long sediment deposition zone at the bottom of the slope for vegetation to establish.

Long slopes in excess of 50 to 100 feet, and moderate to steep slopes that are greater than 5h:1v, should be broken with some type of slope interruption. Runoff from long slopes forms concentrated flow and gullies, so the length of slope and drainage area should be broken into small drainage waterways and basins. These waterways and ridges, in conjunction with slope shape and other microtopographic features, will break a slope and concentrate the runoff in basins where a good vegetative cover will form.

Where possible, tie into existing drainages and low points above and below the disturbance. Grading of waste dumps and tailings may be limited and structures such as terraces maybe the only option for breaking the slopes.

Installation

To create slope shape, start with the average (from toe to crest) slope angle desired, using all materials that go into the fill. Any compaction requirement should be met in this shape. Push material to create and finalize the concave shape.

Problems may occur if:

- Crest is not steep enough. Overland flow from the undisturbed area above the disturbed site may saturate or seep into the fill at the crest of the slope.
- Slopes are very steep. As material is pushed up the slope, the soil at the crest of the slope may be at the angle of repose. This will result in settling.
- Equipment operators are not instructed that the toe will be flatter and the crest of the slope will be steeper than the overall slope angle.

Maintenance

Restrict vehicle use of area.

Vegetative Filter

Vegetative filters are grassy areas, which act as sediment filters. The coarser particles settle as the flow decreases in velocity. The finer particles settle in the lower portion of the filter. Vegetative filters function properly only when flows are not concentrated and in areas of low sediment yield. Vegetative filters in Utah are limited to areas of greater rainfall, usually greater than 18" a year.

Basic Design and Construction

Vegetative filters are predominantly grasses. The grass density needs to be high to effectively filter sediment. Grass species should be coarse so flows will not bend the grass to the ground. It is important that grass species have a rhizomatous, or tillering, root system. Seed catalogues will provide this information. Depending on the treatment area, the vegetative filter needs to be fifteen to thirty feet wide.

Vegetative filters are best suited as a secondary treatment. This technique would be appropriate in areas such as along long narrow corridors, behind silt fences, or next to roadways and railroads.

Problems may occur:

- if too much sediment is deposited and it covers vegetation.

Note: It may take several years to develop sufficient vegetation for filter and alternative means of control should be provided until vegetation is adequate.

Maintenance

Reseed and replant vegetation as needed. Maintain overland flow.

Straw Bale Barrier

A straw bale barrier is a temporary barrier used to intercept sediment-laden runoff and to provide retention of sediment from small drainage areas. A straw bale barrier can be used to promote sheet flow (overland flow) and to reduce runoff velocity, thus reducing erosion and improving water quality. An average straw bale should be thirty inches in length, weigh at least 50 pounds, and contain five cubic feet or more of material. The straw bale should be entrenched and anchored to the ground. The effective life span of a straw bale is normally six months. Therefore, straw bales must be replaced or a new barrier must be placed directly upslope of the old barrier when sediment control is required for longer time periods.

Slope Protection

The maximum size of the drainage area to be treated with straw bales is 0.25 acres per 100 feet of straw bale barrier fence length. Table 7.1 provides more information about hillside length (Roberts 1995).

Table 7.1: Maximum Hillside Length for a Given Slope.

Slope	Slope Length (ft.)
<2%	250
2 to 5%	100
5 to 10%	50
10 to 20%	35
>20%	15

Small Drainage Channel Application

Straw bale barriers may be used where:

- Runoff water quantities are low
- Channel slopes are less than 20% (Ferris et al. 1996)
- The drainage area is one acre or less or where the bales are not likely to be over-topped by runoff

Straw bale barriers should also be used around or down slope of soil stockpiles. However, they should not be installed in areas of highly concentrated flows, such as steep, narrow channels and ditches or in flowing stream channels.

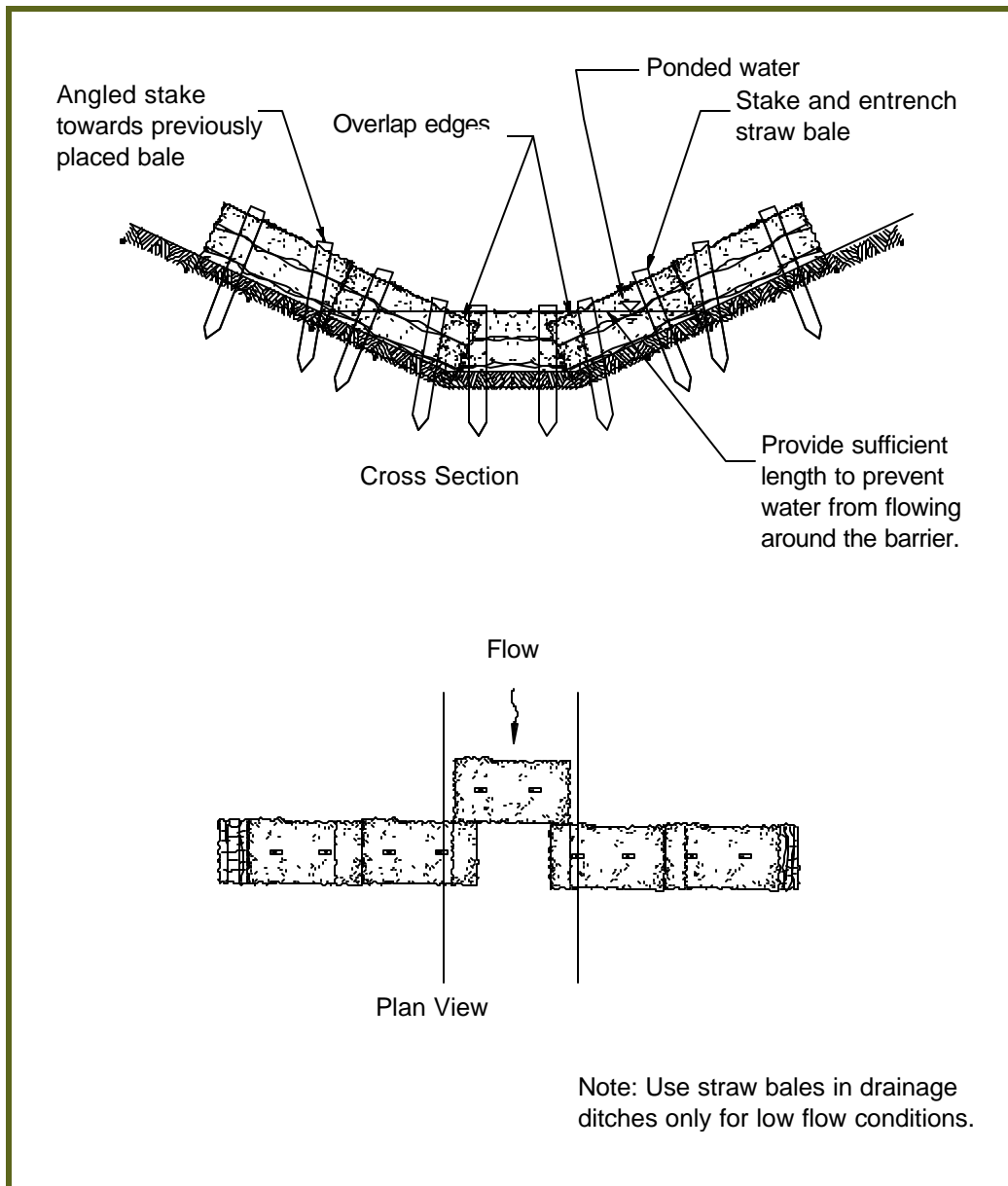

Figure 7.1: Installation of a Straw Bale Barrier in a Ditch

Basic Design and Construction Criteria

To construct a small drainage or strawbale dike, a 4 to 6-inch deep trench should be excavated the length of the barrier and width of the bale.

Excavated material should be placed on the upstream side of the trench. Wire or string-bound bales containing a minimum 5 cubic feet of either hay or straw are to be placed in the trench and are anchored by two 2" x 2" wooden stakes, rebar, or mine roof bolts. These should be driven through the bale into the underlying soil at a slight upstream angle to prevent the bale from overturning. The first stake should also be driven slightly toward the previously laid bale to force them together. Spacing between the bales can be tightly chinked with loose straw. The excavated soil should then be backfilled firmly against the up slope side and compacted.

When using straw bale check dams in swales or ditches, place the barrier perpendicular to the contour. The same installation procedure described above is followed, with the barrier extended up the sides of the ditch until the tops of the end bales are higher than the top of the lowest middle bale. This will create a spillway over the lower middle bales and prevent scouring around the ends of the barrier.

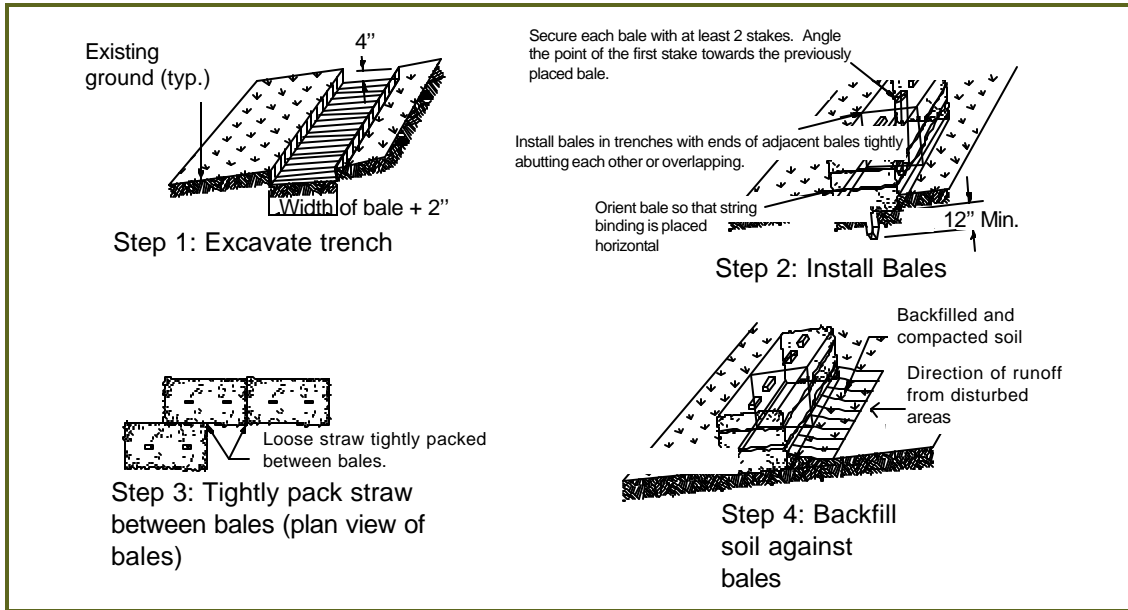

Figure 7.2: Properly staked and entrenched straw bales.

Problems may occur if:

- The drainage area is too large. Break it up into smaller areas.
- Too much sediment accumulates before clean out, causing the barrier to fail. Replace bails more frequently.
- Upstream slope is too steep or too long. Break up the length with additional rows of barriers.
- Undercutting occurs. Entrench the bales at least six inches and compact the loose soil on the upstream side.
- Water seeps between bales without treatment. Tightly chink spaces between bales with loose hay.
- Flows in a drainageway exceed the capacity of the straw bale.
- Erosion occurs around the straw bale fence barrier. Reshape ends to elevation above pool level.
- Animals eat or bed in straw bales.

Maintenance

Bale barriers should be inspected immediately after each rainfall or daily during periods of prolonged rainfall. Damaged bales and undercutting or flow channels around the ends of barriers should be repaired or corrected as soon as possible. Sediment

deposits should be removed after each rainfall, and accumulations should be removed when they reach half the height of the barrier.

Removal

After all sediment producing areas have been permanently stabilized, all sediment accumulation at the barrier trap should be removed and excavation should be backfilled and properly compacted. Grade the site to blend with the terrain.

Silt Fence Barrier

A silt fence is a barrier of geotextile fabric, or filter cloth, used to temporarily intercept sediment-laden runoff from small drainage areas. A silt fence can be used to promote sheet flow, to reduce runoff velocity, and to help retain transported sediment on the site, thus reducing erosion and enhancing water quality. Life expectancy of a silt fence is dependent on ultraviolet stability and type of fabric.

Silt fences are very effective in sheet flow conditions and usually ineffective with concentrated flows. Silt fence and catch basin combinations are effective in a concentrated flow situation. Woven and non-woven synthetic fabrics are available. Woven fabric is generally stronger than non-woven fabric and usually does not require the additional support of a wire mesh. Average life expectancy is dependent on the ultraviolet inhibitor added, but is usually six months to several years.



Figure 8.1: The silt fence is notched in a small drainage situation.

Silt fences are commonly placed at the bottom of a disturbed slope or adjacent to streams and ponds. Silt fences have a lower failure rate than straw bale barriers, but are more expensive. Silt fences can be used for slope protection, in minor swales or ditches, and around storm drains. Do not use where concentrated flows exceed 0.03 m³/s (1cfs) (Roberts, 1995).

Note: Do not construct sediment fences in areas where rock or rocky soil prevents the full and uniform anchoring of the fence toe.

Slope Protection

The maximum size of the drainage area should be 0.25 acres per 100 feet of fence length. The maximum length of slope behind the fence is 100 feet and the maximum slope length for given slopes can be found in Table 8.1. (Ferris et. al. 1996)

Table 8.1: Maximum Slope Length Above a 24" to 30" High Silt Fence

Slope	Length (ft)
<2%	500
2 to 5%	200
5 to 10%	150
10 to 20%	100
20 to 30%	70
30 to 40%	40
40 to 50%	25

Channel and Storm Drain Application

- Filter fences may be used in channels and storm drains for areas draining no more than one acre. They are not for use in perennial channels.
- Filter fences should be used only where the volume of runoff is not expected to exceed one cubic foot per second.
- When using filter fences in channels and storm drains, standard weight synthetic filter fabric or an equivalent should be used.

Basic Design and Construction Criteria

Basic design guidelines are:

- The height of the filter fabric silt fence should be at least 1.25 feet and not exceed three feet.
- The filter fabric should be purchased in a continuous roll and cut to the length of the barrier to avoid the use of joints.
- Wood posts should have a minimum cross sectional area of at least three square inches. Steel posts can be standard "T" or mine roof bolts. Projections for fastening wire mesh are useful on the post. Posts should be at least five feet long and driven at a slight upstream angle into the ground to a minimum of depth of eighteen inches.
- When a wire mesh support fence is used, the wire should be a minimum 14-gauge with maximum mesh spacing of four inches and must be securely fastened to the downstream side of the post.
- If the filter fabric is of extra-strength quality, no wire mesh support is required and maximum post spacing is six feet. Otherwise, wire mesh is required with a maximum post spacing of ten feet.
- A trench should be excavated at least four to eight inches deep and four inches wide along the line of the support posts and upstream from the barrier.
- The filter fabric and wire mesh (when applicable) should be stapled or wired to the post. Then, a minimum of eight inches of fabric is placed into the trench.
- When a filter barrier is constructed across a ditch or swale, the barrier should be of sufficient length to eliminate end flow. Plan the configuration to resemble a horseshoe with the ends pointing up slope. Cut a "V" notch spillway and secure with wire in the center to allow passage of high water and prevent flows around the ends of the fabric.

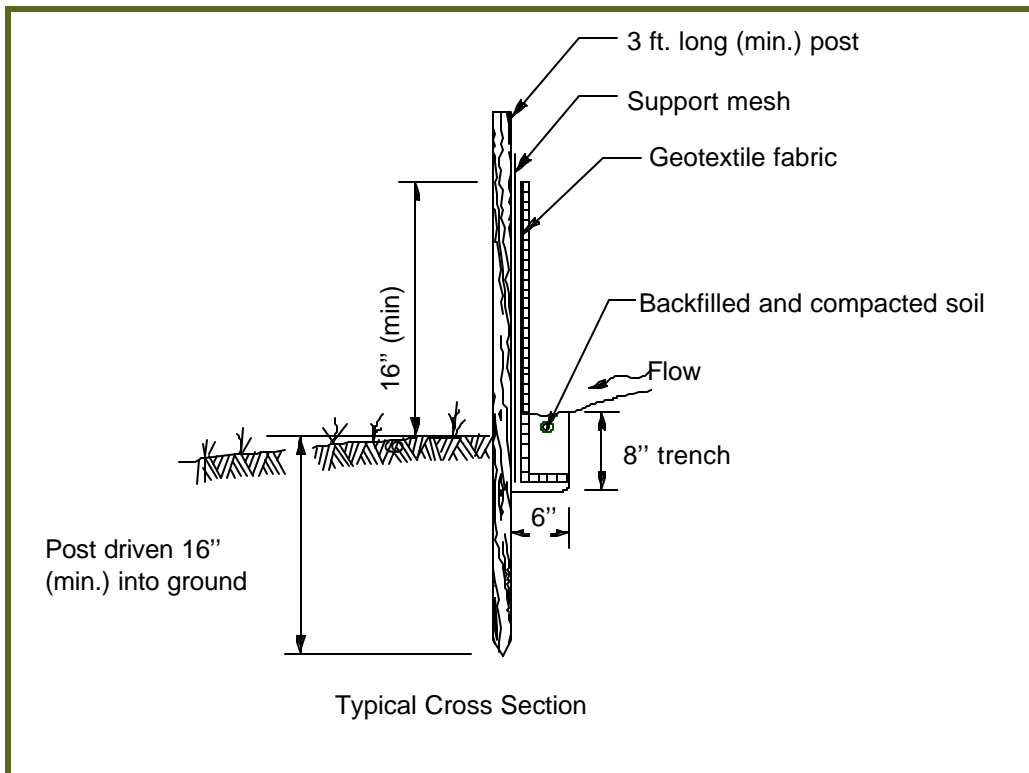

Figure 8.2: Silt Fence Installation Detail

Problems may occur if:

- Installation is done improperly.
- Drainage area is too large. Drainage area needs to be broken up into smaller areas.
- Too much sediment accumulation is allowed before it is cleaned out, causing failure.
- Upstream slope is too steep or too long. Break up the slope length with additional rows of barriers.
- Fence is not adequately supported.
- Flows may exceed the capacity of the fence
- Undercutting occurs because fence was not buried 4" to 8" deep or the trench was not backfilled and compacted properly.
- Fine soils, such as Mancos shale, pipe underneath the fence.
- Erosion occurs around barrier ends due to endpoints being lower than top of temporary pool elevation. Reshape ends to the elevation above pool level or use a "V" notch for a spillway.

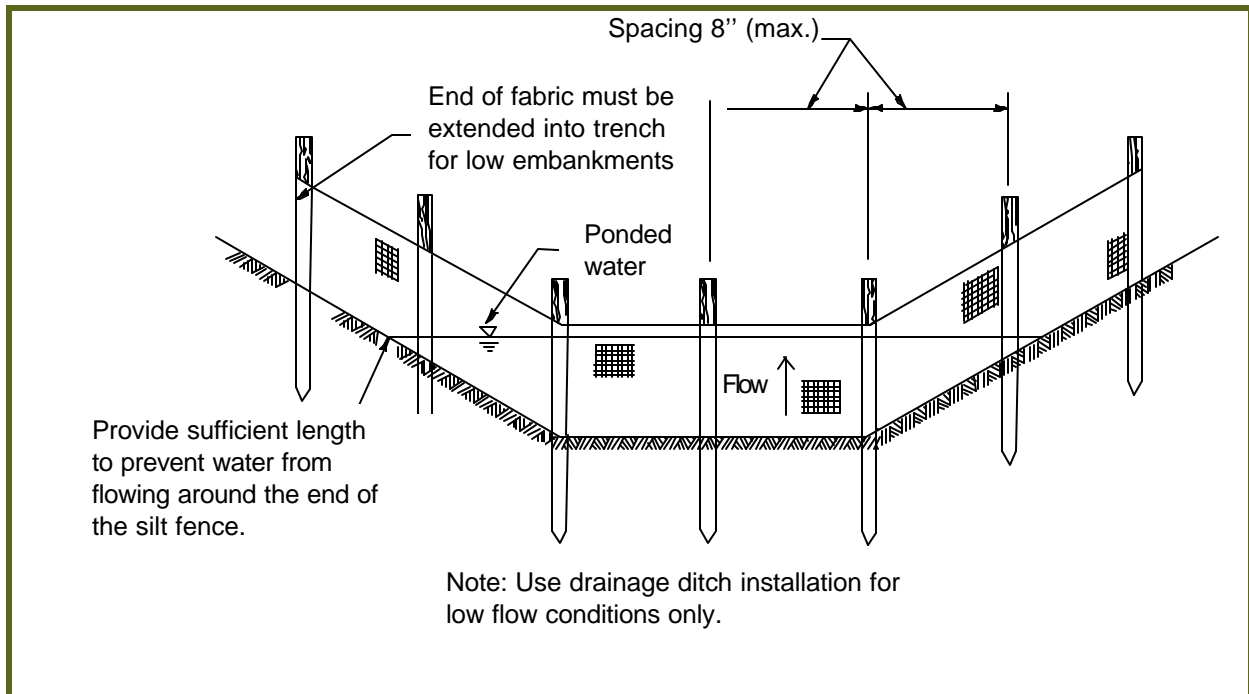

Figure 8.3: Silt Fence Installation in a Drainage Ditch

Maintenance

Silt fences should be inspected immediately after each heavy rainfall event or daily during periods of prolonged rainfall. Damaged fences, undercutting, or flow channels around the ends of barriers should be repaired or corrected immediately. Sediment deposits should be removed after each rainfall. Sediment should be disposed properly to prevent its entry into any watercourse.

Removal

After all sediment-producing areas have been permanently stabilized, sediment accumulation at the barrier trap should be removed and excavations should be backfilled and properly shaped.

Temporary Diversions

A temporary diversion is a berm or swale used to prevent sediment-laden waters from leaving a site and to prevent offsite or upstream waters from entering a site. Diversions are also used to direct the sediment-laden water to a specific control such as a sediment pond. Typical diversions are combinations of berms and ditches and are temporary structures. Temporary diversions used in final reclamation should be removed after

swale: *excavated channel or ditch*

berm: *dike or ridge*

vegetation has stabilized the site. Diversions which are used as drainages for re-establishing the natural drainage pattern though the reclaimed area should be designed as described in (Chapter 2, Section 1).

Diversions are typically used:

- At the toe of cuts or fills to direct sediment-laden runoff to sediment traps.
- At the top of cuts or around disturbed areas to divert clean or undisturbed runoff away from the slope and disturbed area.
- At the top of steep slopes where runoff would cause erosion.
- Around a site to prevent entry of off-site runoff and to reduce flooding.

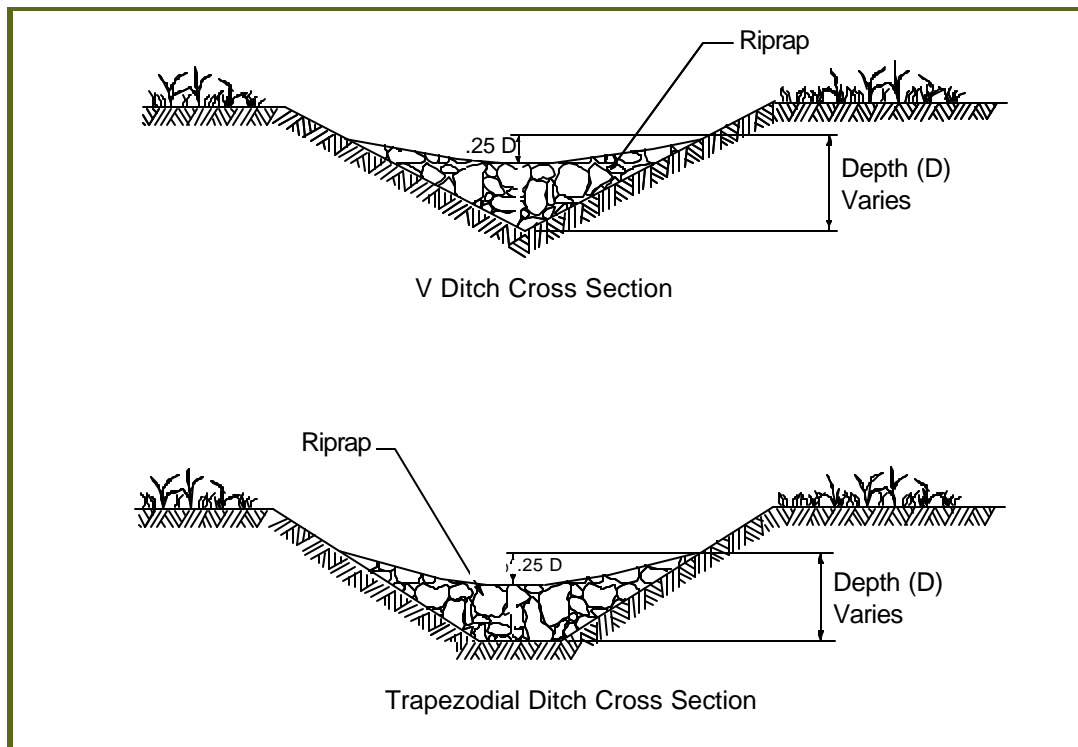

Figure 9.1: Details of a Temporary Diversion.

Basic Design and Construction Criteria

- Design temporary diversions to handle the maximum peak runoff from a 10-year storm.
- Diversions used to channel clean water around the construction site should be constructed after the areas have been cleared but before grubbing and grading operations begin.
- Construct berms of compacted soil with 2:1 side slopes. The height and width of the diversion will be dependent on flows expected or calculated.
- Vegetate diversions immediately after construction unless the diversion will be in place fewer than thirty working days.

Problems may occur if:

- Diversion is not properly compacted. An improperly compacted berm could fail in a heavy storm.
- Grade is excessive. A steep grade requires protective liner use check dams or realignment to reduce grade.
- A change in channel grade or course causes sediment deposition and subsequent overtopping. Realign or deepen channel to maintain the grade.
- There is a low point in diversion. Build up diversion.
- The diversion occurs near a vehicle crossing point. Maintain berm height, flatten side slopes, and protect ridge with gravel at crossing point or change to culvert.
- There is excessive velocity at discharge point. Install stabilization measures such as riprap, energy dissipaters, or geotextile linings.

Maintenance

Check long term temporary diversions after each rainfall until the disturbed areas are stabilized. Inspect temporary diversions once a week, and following each major rainfall event. Remove accumulated sediment from the channel to maintain the design criteria. Check the diversion, swale, and outlets and make necessary repairs immediately. Re-seed areas that fail to establish a vegetative cover. Remove all diversions and blend with the natural topography when the area has been permanently stabilized.

Temporary Slope Drain

A temporary slope drain is a structure used to convey water down the face of a cut or fill without causing erosion. Temporary slope drains are used in conjunction with berms along the edges of newly constructed slopes to prevent erosion. They are used along cut and fill slopes until permanent storm water drainage structures are installed or until vegetation has adequately stabilized the slope.

Basic Design and Construction Criteria

Plastic lining, fiber matting, wooden flumes, metal, rigid, or flexible plastic pipe, and/or half round pipe are commonly used. Provide a smooth, uniform ditch when plastic lining is used to prevent water from overflowing the sides.

Form and compact the base or fill to hold the slope drain in place and to channel water. Construct the inlet to channel water into the drain. Anchor the drains to withstand the force of the water. Anchoring can be accomplished by staking at approximately 10 foot intervals or by weighing down the drains with items such as riprap, sandbags, or compacted soil. Design and construct outlets with items such as dumped rock, small sediment basins, or other energy dissipation devices as the base to reduce erosion downstream.

Install temporary slope drains at frequent intervals along continuous, unprotected slopes and at low points in the roadway profile grade. Do not exceed five acres of drainage area for each slope drain. Pipe connections should be watertight and secure so joints will not separate. Pipe diameters, should be calculated by a qualified engineer for expected flows. Place trash racks at inlet to prevent clogging.

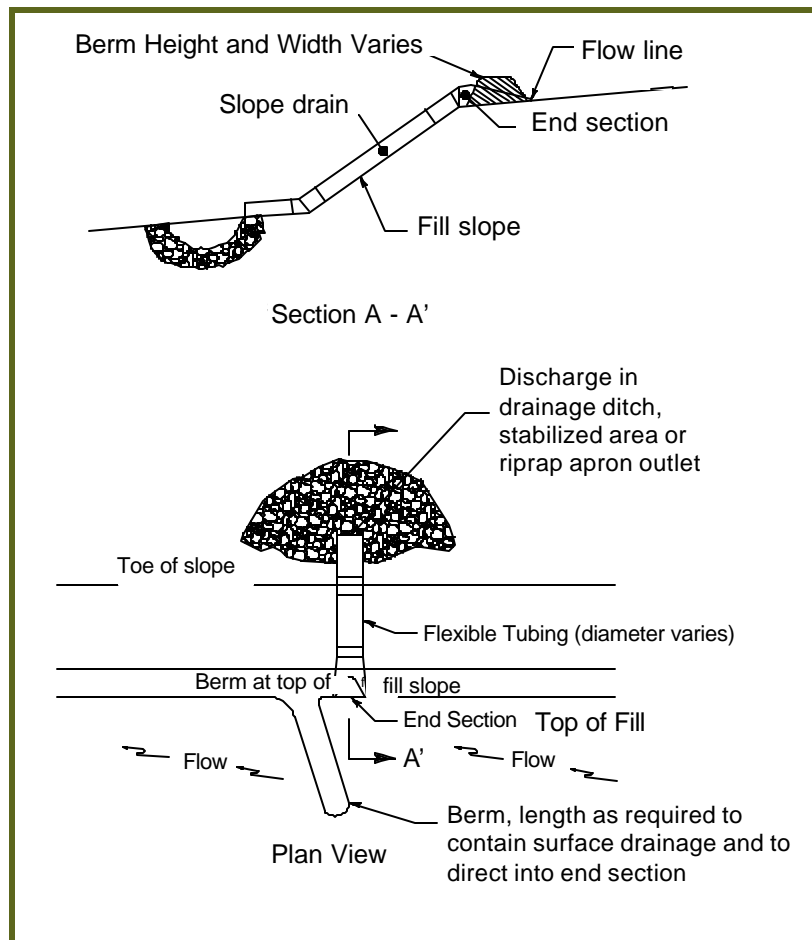

Figure 10.1: Installation of a Slope Drains

Problems may occur if:

- Washout along the pipe, matting, or flume occurs due to seepage, piping, or overflow. Check for inadequate compaction, insufficient fill, installation of drain too close to edge of slope, too steep a slope (open drains), too large a drainage area, or undersized conveyance channel.
- An undersized or blocked pipe causes an overtopping of the diversion. The drainage area may be too large.
- Improper grade of channel and ridge causes an overtopping of the diversion. Maintain positive grade.
- There is erosion at outlet because pipe may not extend to stable grade or outlet. Stabilization structure may be needed.
- Slope drain is displaced or separated because the drain has insufficient anchorage.
- There is erosion after removal. A permanent drainage needed where temporary slope drain removed.



Figure 10.2: Slope drain used to convey drainage over newly reclaimed slope. Horse Canyon Mine.

Maintenance

Inspect temporary slope drains weekly and also following rainfall events. Some critical points that should be checked and promptly repaired are:



Figure 10.3: Slope drain was removed after vegetation was established. Horse Canyon Mine.

- Sediment or trash accumulation at inlet or outlet.
- Settlement of fill over pipe, such as cracking or holes.
- Leaks or inadequate lateral support of conduits.
- Inadequate anchoring, pipes separate down slope.

Removal

Remove all temporary slope drains when no longer necessary and restore the site to match the surroundings.

Outlet Protection

Water traveling through pipes attains a high velocity and can damage the soil at its discharge from the pipe. Outlet protection involves the use of an energy-dissipating device at the outlet of a pipe or conduit to prevent excessive erosion and scour. The most common material used in outlet protection is rock riprap.

Basic Design and Construction Criteria

Riprap Outlet Protection

Excavate the subgrade below the design elevation to allow for thickness of filter and riprap. Compact any fill used in the subgrade to the density of the surrounding undisturbed material. When applicable, smooth subgrade to prevent tear of filter fabric. To prevent subgrade erosion, place the filter stone down prior to placing the riprap. Never use filter fabric except in special conditions.

Ensure a minimum riprap thickness of 1.5 times the maximum stone diameter. Maintain final structure to the lines and elevations as shown in plans, taking care not to place stones above the finished grade. Cement may be used instead of rock, except in final reclamation.

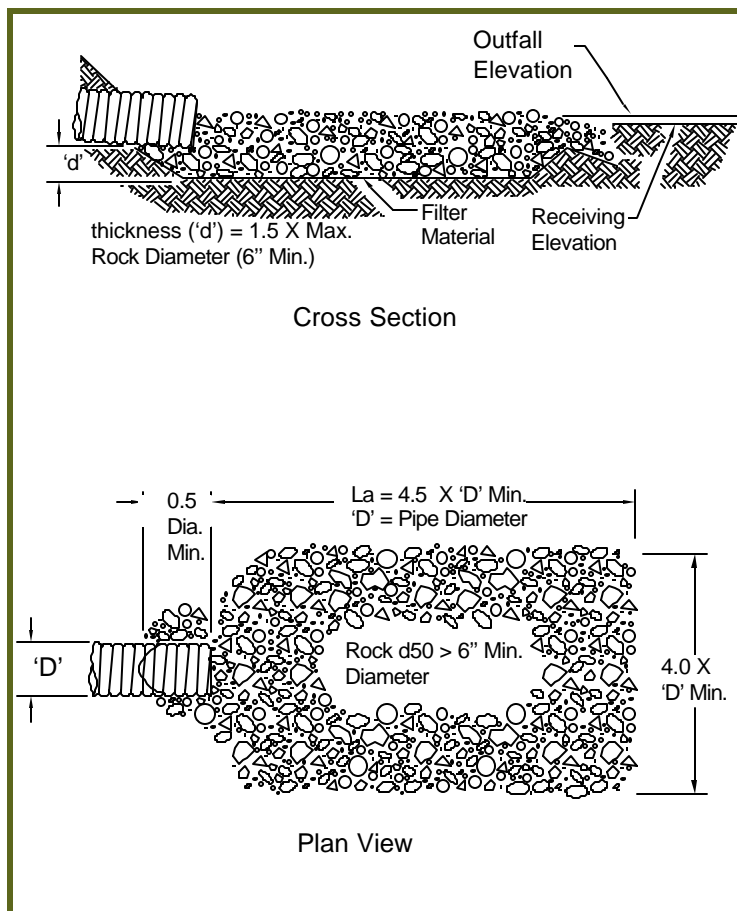

Figure 11.1: Installation of a rock riprap energy dissipator.

Apron Installation

Nondefined Channel:
Aprons should be constructed at zero grade, be aligned so they are straight, and be long enough to adequately dissipate energy. There should be no restrictions from the apron end to the receiving grade.

Well-Defined Channel:
Aprons should be straight and properly aligned with the receiving stream. The apron should extend to the top of the bank and be long enough to adequately dissipate energy. There should be no restrictions from the apron end to the receiving channel.

Problems may occur if there is:

- Erosion around apron and scour holes at outlet. The foundation was not excavated deep enough or wide enough, consequently the riprap restricts flow across the section.
- Erosion downstream. This indicates the riprap apron is not on zero grade.
- Movement of stone and downstream erosion. Stones are too small, too round, not angular, or not properly graded.
- Downstream erosion. Riprap was not extended far enough to reach a stable section of channel or adequately dissipate energy.
- Stone displacement and erosion of subgrade foundation. Appropriate filter not installed under riprap-this is a common problem.

Maintenance

Riprap outlet structures do not require much maintenance when properly installed, however, they should be checked after heavy rains for erosion at sides and ends of the apron and for stone displacement. Repair damage immediately using appropriate stone sizes.

Inlet Protection

Inlet protection is a temporary barrier used to prevent sediment from entering and clogging the drainage system. This practice helps to keep the conveyance channel free from debris or sedimentation that could reduce the capacity of the channel. The basic principle is to provide a relatively small detention basin or filter before the inlet, allowing sediment to settle before entering the conduit or channel. Unlike the conduit or channel, this filter is readily accessible for sediment cleaning and maintenance. Inlet protection is a secondary measure for sediment control and some type of stabilization should be in place to reduce erosion at the source.

Basic Design and Construction Criteria

There are several methods of inlet protection. Each procedure requires excavation and/or the use of a dike or berm for establishment of a drop area. Drop areas are used to promote ponding that allows for settlement of sediment and to help prevent flow bypass of the inlet.

The most common inlet protection methods are:

- Small detention basin
- Straw bale drop
- Filter fabric
- Trashrack

Straw Bale Drop Inlet Protection

Straw bale drop inlet protection is useful for maximum drainage areas of one acre. Use straw bales as described in [Part 2, Section 7](#). Bales are placed in a 4" to 6" deep trench dug around the inlet and are staked in accordance with the requirements for a straw bale barrier. Bales can be anchored in areas where trenching is not feasible, such as a finished road surface, by placing gravel around the base of the bales. Be sure to tightly chink spacings between bales with loose straw to prevent the free flow of sediment-laden runoff.

Filter Fabric Inlet Protection

This type of protection is useful for maximum drainage areas of one acre. Use extra-strength quality fabric, which is resistant to ultraviolet degradation, especially if the duration of use will exceed 60 days. A wire fence may be necessary to support the fabric. The fence should be 14-gauge minimum with a maximum mesh spacing of 6 inches.

Use either steel fence support posts or 2" x 4" wooden post, each at least three feet long. The structure must support a 1.5 foot head of water and sediment without collapsing

or undercutting. Drive posts approximately 1.5 feet and when necessary, include top supports to prevent collapse of the structure.

Use a continuous sheet of fabric. Place at least eight inches in a trench to prevent undercutting, then backfill and compact with soil or crushed stone. Secure fabric to the post or support fence, stretching fence to top level. The top should be level to help provide for uniform overflow.

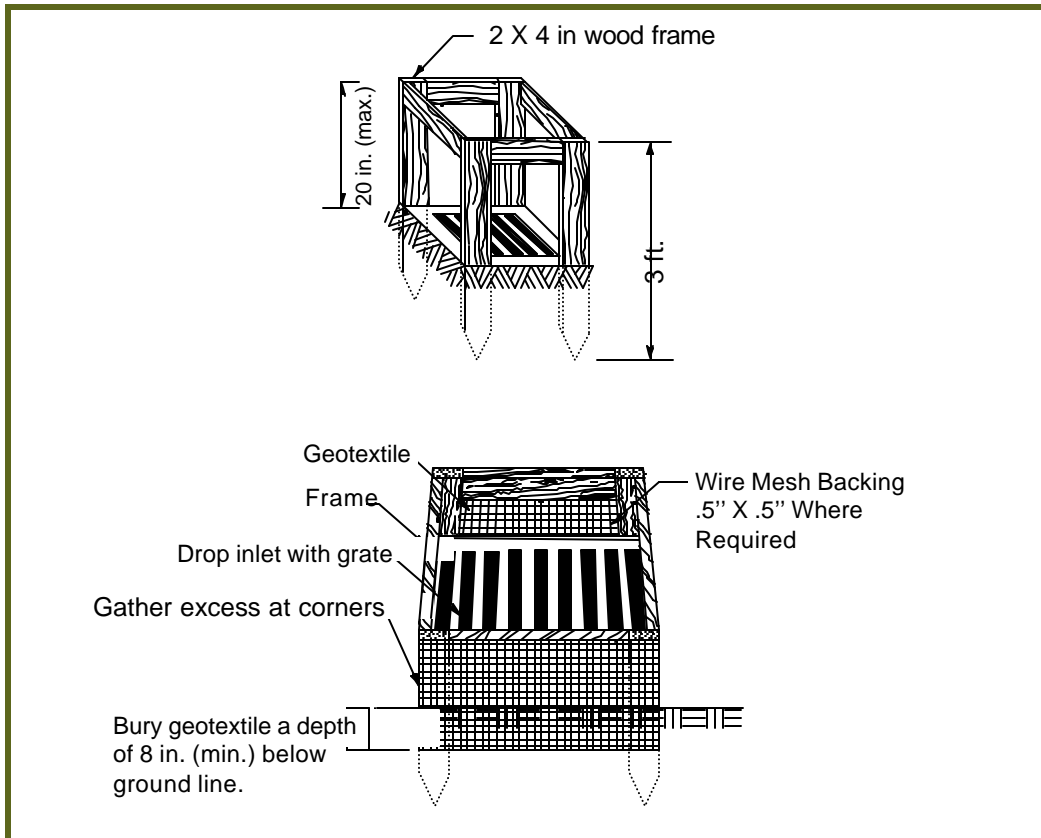

Figure 12.1: Installation of Silt Fence Drop Inlet.

Trashrack Inlet Protection

Trashrack inlet protection is used to prevent debris from entering culverts. Trashracks should, at a minimum, be used when large ephemeral or intermittent flows are routed through culverts. Trashracks are installed at a low, designed, angle so that as debris accumulates, it will move over the rack and not impede flow. The trashrack is solidly fixed

and not moved during stream flow events. Provisions for removal are needed to facilitate culvert clean out. All trashracks and culverts should be inspected regularly to determine if debris has accumulated. If so, debris should be cleaned out.



Figure 12.2: Trashrack installed to protect debris from entering the culvert. Horizon Mine.

Problems may occur if:

- Sediment fills the trap and enters the storm drain. The inlet may require maintenance or the sediment-producing area may be too large for the trap. Failure to remove sediment may result in inadequate storage volume for next storm.
- There is excessive ponding around inlet because the filter may be clogged with sediment. Remove debris, clear sediment, and replace filter device being used.
- The inlet is eroded and undercut. If this happens, install protection device against inlet.
- Flow bypasses the storm inlet. Maintain the temporary dike below the inlet.
- The structure collapses. Support post and fabric at the top or reduce height of fabric barrier construction.
- The structure is undercut. Bury fabric at the bottom according to installation design.
- Flooding and erosion occur due to blockage of the inlet. Install a trashrack.

Maintenance

Maintenance of the inlet ensures its effectiveness. Inspect inlets following each storm and remove accumulated sediment and debris regularly. Make any needed repairs immediately.

Check Dam

A check dam is a small barrier constructed in a drainage way to reduce channel erosion by reducing the flow velocity. Check dams are appropriate for use in small drainage, but are not for use in perennial streams.

Check dams are useful:

- In temporary swales and ditches where lining with non-erodible materials is not practical, but erosion protection is necessary.
- When construction delays or weather conditions prevent timely installation of non-erodible lining.
- In either temporary or permanent ditches or swales which need protection during the establishment of grass linings.
- In remote settings that may be inaccessible to equipment.

Basic Design and Construction Criteria

Check dams are usually constructed of riprap, logs, sandbags, and straw bales to a maximum height of 2 feet.

- The drainage area above the check dam should be between two and ten acres (Wham 1993).
- Space multiple check dams so that the bottom elevation of the upper dam is the same as the top elevation of the next dam downstream.
- The center of the check dam should be a minimum of 9" lower than the ends to act as a spillway for runoff.
- Stabilize overflow areas to resist erosion.
- Use three inch or larger stone for stone check dams. Make side slopes of 2h:1v or flatter and key into the sides and bottom of the channel a minimum depth of 2 feet. Gabion baskets can be used to contain the stones.
- Construct log dams with 4" to 6" diameter logs. The ends should be embedded a minimum of 2 feet. Note that the removal of a log check dam can result in more soil disturbance than the removal of other types of check dams.
- In areas of low flow, straw bales are effective. Overlap and entrench the bales a minimum of 4" and anchor with stakes so the top of the stakes are pointed slightly upstream.

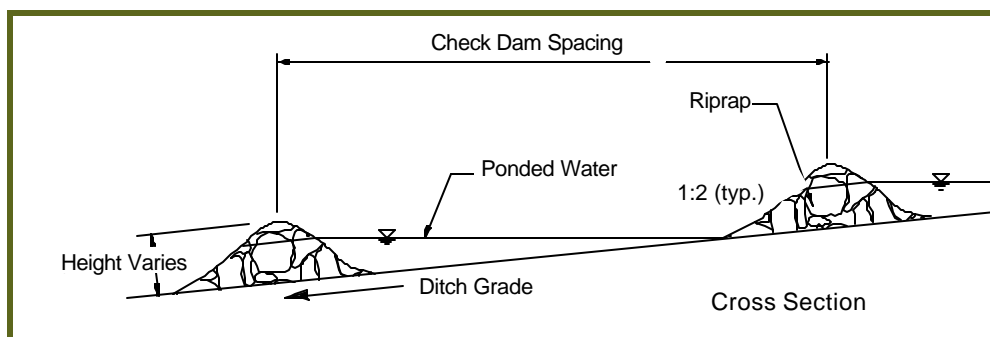

Figure 13.1: Details of check dam installation.

Problems may occur if there is:

- Sedimentation. Check dams are designed for velocity reduction and erosion control. Although sedimentation is not intended, it often occurs. Sediment clogging the dam and ponding water may kill the vegetative lining if plants are submerged too long after rain or if siltation is excessive.
- Downstream erosion. Stabilize the streambed and bank with riprap or equivalent. Extend downstream embankments to stable grades.
- Overflow at the abutments. Lower or notch the spillway.

Maintenance

Regularly inspect a check dam to ensure the dam has not been breached or otherwise damaged. Check the center elevation of the dam to ensure that it is lower than the ends of the dam.

Remove sediment accumulation behind the dam to prevent damage to channel vegetation and to allow the channel to drain through the dam. Otherwise, remove sediment when it reaches half the height of the dam.

Repair a damaged check dam promptly so the check dam will be fully functional for the next runoff event.

Removal

Remove check dams when intended use is completed.

Temporary Sediment Trap

A temporary sediment trap is a control device used to intercept sediment-laden runoff, to trap sediment, and to prevent or reduce offsite sedimentation. A temporary sediment trap is formed by excavation or construction of embankments. A temporary sediment trap may be located in a drainage way, at a storm drain inlet, or at other points of discharge from a disturbed area. However, a temporary sediment trap should never be located in a streambed. A trap may be constructed independently or in conjunction with diversions. Ordinarily, the trap is located where it is easily accessible for clean out by heavy equipment and used to prevent excessive siltation of other structures. For example, a temporary sediment trap may treat water before it enters a sediment pond, thereby reducing sediment pond cleaning frequency.

Basic Design and Construction Criteria

Excavated sediment traps are preferred over a sediment check dam because an excavated basin is cheaper to construct and easier to maintain. Excavated basins cannot breach and lose the previously deposited sediment.

The design is based on the expected runoff volumes for the treated area. Sediment traps should be sized to handle the expected volume of sediment trapped. The traps should be designed to control the sediment from the calculated peak rates of runoff from a 10 year frequency storm.



Figure 14.1: A temporary sediment basin located in a small drainageway using filter fabric. Willow Creek Mine.

Problems may occur due to:

- An inadequate spillway size or construction, resulting in the overtopping of the dam, poor trap efficiency, or possible failure of the structure.
- A low point in the embankment because of compaction and settling, resulting in overtopping and possible failure.
- The outlet not extending to the stable grade, resulting in erosion below the dam.
- Inadequate vegetative protection, which can result in embankment erosion.
- Inadequate storage capacity because the sediment is not removed from basin frequently enough.



Figure 14.2: A temporary sediment trap near a washdown bay should be easily accessible for clean out by heavy equipment. SUFCO Mine.

Maintenance

Inspect temporary sediment traps following each significant rainfall event and repair any erosion and piping holes immediately. Clean out the trap when sediment reaches $\frac{1}{2}$ the design depth. A stake set at the clean out level is helpful. Gravel facing should be cleaned or replaced if clogged.

Removal

Do not remove the sediment trap until all sediment producing areas have been permanently stabilized. The accumulated sediment in the trap should be removed or properly compacted and blended with the terrain.

Sediment Ponds

Sedimentation ponds and siltation structures are used to minimize sediment contributions to surface waters. Sedimentation ponds retain water, slowing the velocity so that sediment can settle to the bottom of the structure. Sediment ponds can also reduce the peak flow rate from the drainage area to surface water.

Sedimentation ponds can be excavated or may be constructed with an embankment of earthen materials. For most purposes, it is recommended the ponds be located outside of natural drainages. If the site is located in a drainage, the water produced up-gradient from the site should be routed through an adequately sized culvert under the disturbed area and sedimentation pond or around the disturbed area. When conducting open-pit mining, the sedimentation pond is often the pit and the disturbed area drainage should be directed to the pit where possible.

peak flow rate: *the actual or calculated maximum volume of runoff per unit of time. The peak flow rate gives total volume calculated which helps determine the size of the pond required to control the volume of water from a known storm event.*



Figure 15.1: Typical sediment pond design. SUFCO Mine.

The major differences between a sedimentation pond and a siltation or retention structure, is size and function. Siltation or retention structures are generally smaller and can be used to supplement sedimentation pond effectiveness by collecting sediment prior to reaching the pond. They retain a smaller volume of water and may be used for washdown bays or other areas where operations concentrate excess sediment.

Sedimentation ponds should be located and designed such that structure failure would not result in the loss of life, damage to homes, commercial buildings, highways, and streets, or the interruption of services or public utilities. If the pond can store greater than twenty acre feet of runoff or can impound water up to twenty feet above the toe of the structure, Mining Safety and Health Administration (MSHA) requirements will apply. The site operations may require compliance with additional state and federal laws associated with sedimentation ponds. Some of these laws are identified in [Table 15.1](#).

Table 15.1: Possible sediment pond permit requirements.

Government Agency	Permit	Internet Web Site
Department of Environmental Quality	Point and non-point * discharge permits	http://www.eq.state.ut.us/eqwq/updes_f.htm
Division of Water Rights	Dam Safety Water Right	http://nrwrt1.nr.state.ut.us/
Mine Safety and Health	MSHA pond requirements	http://www.msha.gov/

* Utah Pollutant Discharge Elimination System

Basic Design and Construction Criteria

Design and construction should be done by a qualified, certified engineer. Some basic design considerations include:

- Appropriate foundation studies for the structure size and design. Studies may need to consider saturated embankment conditions and earthquake hazards.
- An adequate excess of embankment material is needed to maintain embankment design elevation following settling.
- Embankment construction should provide adequate compaction through engineered designs for lift thickness, moisture control, proper gradation of fill, appropriate trench width and depth, and scarifying the previous lift.
- Over-steepened pond in-slopes or out-slopes should be avoided.
- An effective length-to-width ratio of greater than two should be provided, where width is the surface area and effective length is the length of the flow path. Baffles, check dams, and turbidity currents can be added to increase the flow path or redirect and slow outflow.
- The inflow location should be placed as far away from the outlet as possible.
- Basin shape and depth need to be adequate to provide proper runoff storage detention time, sediment storage, and peak outflow rates.
- Pond design needs to consider access for cleaning out sediment, decanting operations, and sampling outflow water for permit compliance.
- Pond sediment removal should occur when sediment capacity reaches 60% of the maximum sediment storage design. Sediment clean out should occur

before maximum capacity is reached to maintain storage for the next precipitation event so the maximum sediment level is not exceeded. Ponds with constant discharges will require an area draining to the pond for drying of cleaned sediment or an alternative pond.

- Seepage and potential embankment failure can be reduced by providing cut off trenches and anti-seep collars. These are standard practices for trickle tube or drop inlet spillways.
- There must be a method for decanting the pond. The decant should be placed above the maximum sediment level.
- Inlets should be designed to be non-erosive.
- Non-woody species should be used to revegetate riprap embankment out-slopes.
- A regular inspection and maintenance schedule must be provided. This might be dictated by a regulatory requirement.

Spillways

All sedimentation ponds should consider the potential for outflow from a pond. Even a pond sized for total containment for the maximum probable precipitation event should consider where water will flow if the pond is overtopped. A spillway is a designed structure provided to control the outflow from a pond and to safely convey the water in a manner that minimizes erosion and protects the structure.

There are two types of spillways, emergency and primary. The emergency spillway is typically a broad-crested weir that moves from a low slope to a steepened slope. The point of slope break is called the control. The emergency spillway serves to protect the structure and control the flow when the pond discharges and when the primary spillway can not handle the flow volume. A primary spillway is generally used for more frequent discharges and is often a trickle tube or drop inlet for sedimentation pond designs. The primary spillway helps control the outflow rate and detention time of a sedimentation pond. A decant enables the spillway to empty the pond for sediment clean-out and to maintain the detention time between storms that occur in close sequence.

Standard engineering practices include:

- Providing an oil skimmer if oils and non-miscible products will be used within the operation area draining to the pond.
- Retaining 1-foot minimum elevation (freeboard) between the highest emergency spillway flowline and the minimum embankment height.
- Retaining 1-foot minimum elevation (freeboard) between the principle spillway flowline and the minimum elevation of the emergency spillway.
- Providing a trashrack to prevent the spillway inlet from clogging.
- Providing an anti-vortex device to prevent erosion of the embankment near the spillway.
- Designing the outlet to be non-erosive.

Sediment Pond Performance Improvement

The basic way to improve sediment pond performance is to reduce all materials entering the pond, including water. This principle can be implemented during the initial design of a sediment pond, as well as added to existing ponds. When completed during initial design, the sediment pond can be made smaller, saving construction costs. When done to retrofit an existing pond, the clean out frequency can be reduced. Improving pond performance has the desirable combination of saving money and improving environmental conditions. Implement as many of the following guidelines as possible.



Figure 15.2 A sediment trap with baffles is used to treat water to entering the sediment pond. Deer Creek Mine.

1. Use baffles or deflectors to divert water inlets to the pond. This reduces the horizontal flow velocity of that water. 90° elbows also work. Other factors, such as cold or salty water will sink and become stratified to the point of having a thermocline or halocline. Water flowing horizontally can "short circuit" and go directly across the pond with the minimum retention time. Forcing the water to flow straight down or sideways, increases the flow path and retention times. This allows fine material to settle out.
2. Reduce or eliminate all sediment sources within the disturbed area. Look for sources that can be managed and reduced. Successful treatments include the following:
 - Plant vegetation on bare ground.
 - Put gravel surfacing on easily eroded areas such as road shoulders and steep embankments.
 - Install hard surfaces or use soil binders on dirt roads to reduce sediment generation.
 - Provide sediment traps at the source of coal fines and sediment. Examples include coal conveyor belt wash down areas and vehicle wash areas. Make the traps easily accessible for clean out.
3. Reduce volume of water requiring treatment. Use diversions to route water around the site.
4. Install easily-cleaned sediment traps in the channels flowing to the sediment pond. Design the traps to be cleaned with existing equipment, such as backhoes. It's much easier, faster, and cheaper to clean out traps than to clean out the main pond. Some mines have installed concrete traps right in the sediment pond. Such traps, especially those with baffles, catch the coal fines and sediment before they enter the sediment pond. Without baffles, the traps sometimes form a thick skin of coal fines on top of the water and do not perform as well. Make the first baffle with perforations and the others with notches similar to those described below for sediment pond baffles.

5. Install well-designed series of baffles in the sediment pond. When the pond is drained down for clean out, it is a good time to add baffles. Good designs include the following:
- Completely seal the baffles to the bottom of the pond. This is important because if the baffles are not sealed, water and sediments can bypass the baffle by flowing underneath it. Many ponds stratify because cold water from snowmelt and dense water made up of dissolved solids settle to the bottom. This stratified water and water with horizontal velocity can flow under the baffle, carrying sediments with it. Because sediments are messy, it's harder to seal the baffle to the bottom when retrofitting a pond than when first constructing the pond. Therefore, it is cheaper to baffle a pond during initial construction.
 - Make all baffle heights one foot above the maximum expected water level.
 - Make the first baffle nearest the inlet end of the pond with perforations. Most sediments are trapped behind the first baffle, so locate it for easiest clean out.
 - Make all other baffles solid, without perforations, and install notches on alternating sides of each baffle. This forces the longest water flow path to be at the pond surface with quiet water below.
 - Start with a few baffles and monitor pond performance to see if additional baffles are needed.
 - Make the baffles of the material most appropriate for the particular project. Examples include pressure-treated plywood and fabric supported by 6"galvanized wire mesh. Fabric alone can sag and be torn with sediment loads. Support the baffles to prevent damage from sediment loading. When using fabric baffles, be sure to reinforce the holes and notches so they will not tear.

Problems may occur if:

- Soil and chemical conditions that addition of a flocculent and do not receive one.
- Materials and chemical nature prevent materials from settling. High SAR, pH, and low ionic strength are conditions conducive to high suspended solids. Other mechanical methods to eliminate particles may be necessary or non-standard flocculent may be needed.
- The change in base elevation when ponds are created or reclaimed in a drainage leads to upstream channel de-stabilization.

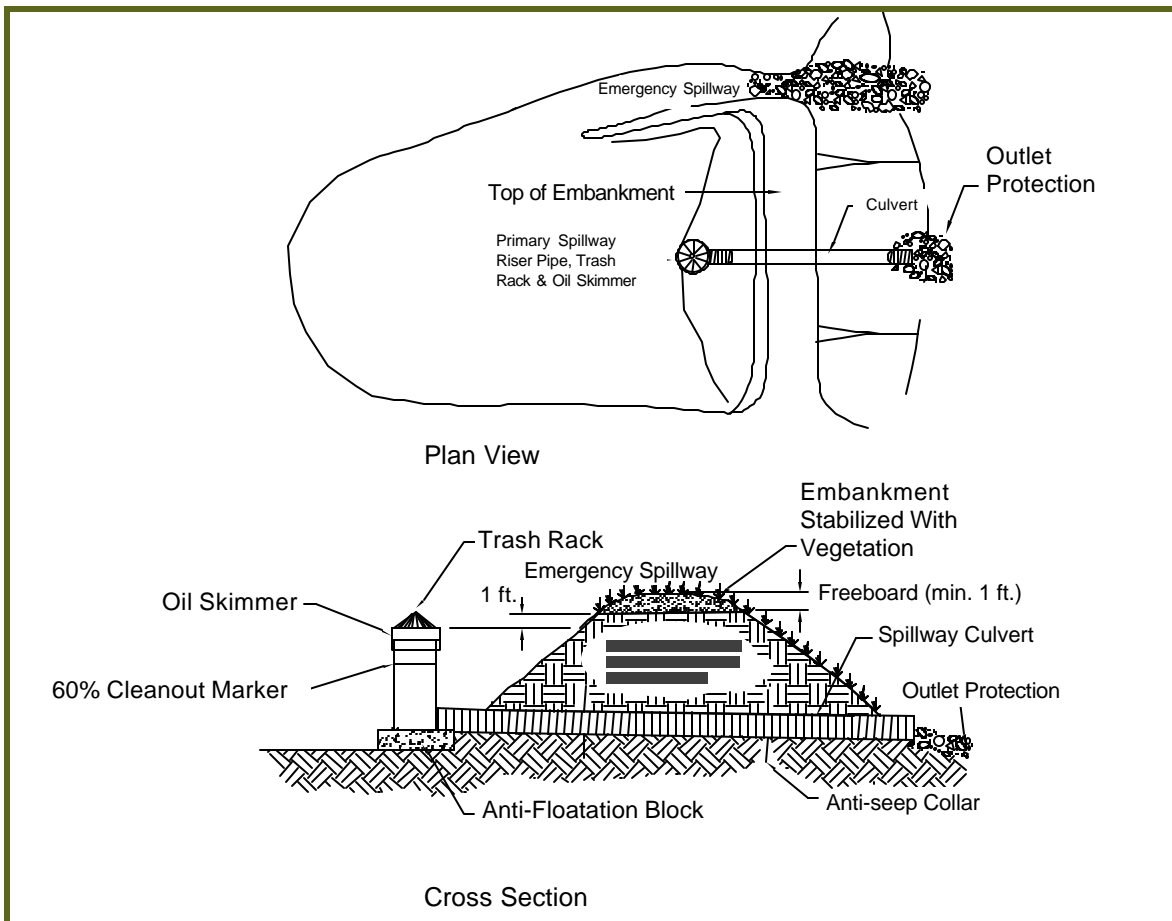

Figure 15.3: Typical elements of a sediment pond.

Maintenance

Inspect sediment basins following each significant rainfall event, repairing embankment, spillway, and outlet erosion damage. Remove trash and other debris from riser, spillway, and pool area. Look for signs of piping, settlement, seepage, or slumping on the embankment and repair these problems immediately. Remove woody vegetation from spillways and embankments.

Locate the clean out elevation at 50% of the design volume; a stake placed at this elevation can be helpful. Use green, yellow, and red-colored stakes as indicators of sediment level. The top of the yellow color is the clean-out level. Haul sediment to designated disposal location.

Removal

After the drainage area has been permanently reclaimed and stabilized, the sediment pond may be drained and the site blended with terrain.



Resources

- **Maps**
- **Activity Checklist**
- **References**

Maps

Most of the information necessary for permit approval can be presented in reclamation plans through drawings, photographs, and maps. Maps that are clear, concise, accurate, and legible are essential to the permitting process and the success of the mining operation.

Reclamation plans must include maps and drawings that depict site conditions throughout all phases of operations. The development of an accurate set of base maps from which operation and reclamation plans are created are critical to each phase of an operation, including:

- exploration
- feasibility studies
- transportation
- resource information about soils, vegetation, wildlife, hydrology, zoning and land use, geology, and topography
- mine layout and design
- mine plant design
- utilities
- reclamation treatments, such as backfilling and grading, drainage design, soils, and vegetation

Aerial Photography

This section provides details about the advantages and disadvantages of using aerial photography in reclamation plans. Although aerial photographs also have some limitations, many can be corrected and the advantages of aerial photography greatly outweigh the costs.

Advantages:

- A wealth of ground detail, such as boundaries, isolated trees, small clumps of bushes, rock outcrops, and buildings can be seen clearly in an aerial photograph.
- Base maps can be constructed from aerial photographs economically and in a reasonable time.
- The photographs can be enlarged or reduced.

Disadvantages:

- Elevations are not shown.
- Scale is not precisely uniform.
- More sheets are required when using larger maps.
- Adjoining photographs may use different scales.

- Distances and directions cannot be measured as accurately as they can on topographic maps.
- Detail is not always legible.
- More skill is required to interpret photographs than to read topographic maps.

Types of Aerial Photography

Aerial Photography

Aerial photographs are available as panchromatic, color, or infrared photography. Panchromatic photography records each color as a different shade of gray. Most modern black and white photography is of excellent quality. Because of their quality and economy, photographs made from panchromatic film are the most commonly used type of aerial photography.

panchromatic:
black and white

High-altitude aerial photographs are particularly suitable, as are orthophotographs in the planning phases of map development because both have relatively accurate horizontal scale. These photos can be used to directly delineate regional features that may be required, such as drainage areas, soils, vegetation, access roads and utility corridors, and proximity to other features such as houses, public roads, and drainages.

Color Photography

Color photography records surface features in the colors of the visible spectrum. The colors on the print are about the same as the colors of the features. The colors may differ according to factors such as sun angle, atmospheric conditions, delays between flights, and surface moisture. The cost for obtaining color photography is about 1.5 to 2 times as much as panchromatic photography. Color prints cost 2.5 to 4 times as much as black and white prints. Excellent black and white prints can be made directly from color negatives at the same cost as prints from panchromatic film.

Infrared Photography

Infrared photography records a portion of the spectrum that is not visible to the human eye. Infrared film is also sensitive to part of the visible spectrum, but true infrared photography is exposed through a deep red filter so that only the infrared radiation is recorded. Infrared distorts and shades particular features. This is especially useful in identifying bodies of water, seeps and springs, vegetation types (including plant disease, drought, and stress), and other features such as roads, ditches, and disturbed areas. Infrared aerial photography is especially valuable in areas that have atmospheric haze because the film is not sensitive to the blue portion of the spectrum that is normally associated with haze. Infrared photography costs about ten percent more than panchromatic photography.

Color infrared photography is sensitive to the green, red, and infrared portions of the electromagnetic spectrum. It produces false colors for most objects. The prints are

spectacular, with brilliant, contrasting colors. This type of photography is especially useful for the study of vegetation. Vigorously growing vegetation appears in vibrant red. Color infrared photography costs about the same amount as conventional color photography.

Table 1: Aerial Photography Comparison.

Type	Base	Advantage	Disadvantage	Cost
Contact prints	Original negatives	Good resolution	Scale cannot change; Errors not corrected	Economical
Enlarging	Prints	Common scale; Tilt corrected	Cannot be enlarged more than 5 times	Latter savings recognized
Orthophotographic	Converted by rectification		Correct scale; Positional accuracy; Meets NMAS standards; Used for base and topographic maps; Some available from USGS (7 1/2 min.)	Similar to controlled mosaic
Aerial Mosaics	Assembling individual pieces	Control mosaic: Close to scale	Uncontrolled mosaic: No geographic control	

*NMAS - National Map Accuracy Standards

Ordering and Planning

When ordering and planning new photography, the following items should be considered:

- Time must be allowed for preparing specifications, awarding contracts, photographing the area, and inspecting the site.
- Ground surface and trees should be bare and other vegetation at a minimum for the best results.
- Factors as geographic latitude and solar altitude must be considered in scheduling flights to reduce or eliminate objectionable shadows.

Aerial photography map scale and accuracy

When considering costs of map production, the following should be considered:

- field surveying and ground control
- flight time
- stereo modeling and plotting
- editing and verification of manuscripts generated from the stereo plots

- drafting and editing to delineate and identify map features
- production of reproducible mylar maps, orthophotos, contact prints, and digital formats for utilizing the maps in computerized mapping and modeling software

Selecting the mapping base affects the accuracy of a map, the methods and costs of map construction, and the quality of the produced map. Purchasing new or recent photography and preparing field sheets at the dimension and scale that will be used for map production is an economically and strategically sound practice. Some of the costly steps of map compilation can be eliminated.

Once the photography has been completed, plotting and digitizing of the information can occur at any time. Considerable savings can be afforded by allowing the mapping contractor an extended period of time to complete the work.

The following chart can be used as a guide for determining aerial photography requirements based on intended map scale and accuracy.

Table 2: Aerial Photography and Mapping.

Maps					Photos			
Map Scale	Map Contour Interval (ft.)	Map Contour Accuracy (ft.)	Map Scale Accuracy (ft.)	Cross Section Accuracy (ft.)	Photo Negative Scale	Camera Altitude (ft.)	Forward Gain 60% Overlap	Usable Width 30% Overlap
1"=30' 1"=40'	1	0.5	1.25	0.30	1"=200'	1200	720	1260
1"=40' 1"=50'	1	0.5	1.25	0.30	1"=260'	1560	936	1638
1"=50' 1"=100'	1	0.5	1.25	0.30	1"=330'	1980	1188	2079
1"=100' 1"=200'	2	0.7	2.0	0.40	1"=400'	2400	1440	2520
1"=100' 1"=200'	2	1.0	2.5	0.50	1"=660'	3960	2376	4158
1"=200' 1"=400'	4	1.4	5.0	1.00	1"=800'	4800	2880	5040
1"=200' 1"=400'	4	1.7	5.0	1.00	1"=1000'	6000	3600	6300
1"=200' 1"=400'	5	2.5	5.0	1.25	1"=1320'	7920	4752	8316
1"=400' 1"=1000'	10	3.5	10.0	2.00	1"=2000'	12000	7200	12600
1"=400' 1"=1000'	10	5.0	10.0	2.50	1"=2640'	15840	9504	16632

Map Types

The most commonly used maps in reclamation are topographic maps and digital maps. This section also covers map scale, standard symbols, and accuracy standards. It is important to remember that maps protected by copyright cannot be reproduced without permission.

Topographic Maps

Topographic maps, which are commonly referred to as "topo" maps or contour maps, are not photographs. On topographic maps, contour lines are used to outline or project vertical elevations on the drawing. The greater the distance between contour lines, the steeper the slope of the land. A grid is used to horizontally locate features on the map using any variety of coordinate systems.

Topo maps are created at varying scales to show horizontal and vertical location. To achieve the accuracy necessary for reclamation plans and the permitting process, additional maps and drawings must be created at scales larger than those currently provided in the Federal and State agency maps.

In the United States, most standard topographic maps are published by the U.S. Geological Survey (USGS). Standard topographic maps are published in quadrangles bound by lines of latitude and longitude. Generally, topographic quadrangles cover 30 minutes, 15 minutes, 7½ minutes, or 3¾ minutes of latitude and longitude. Scale varies with topography and contour interval. The most common publication scales are 1:24,000 (the largest generally available), 1:25,000, 1:31,680, 1:48,000, 1:62,500, and 1:63,360. Maps displaying coverage at 1:250,000 are compiled from larger scale maps and distributed by the Geological Survey to show the entire country. A newer series of maps at scales of 1:50,000 and 1:100,000 is available for certain areas. The smaller scale maps are useful as the bases for general maps, for reference, and for regional features. However, published topographic maps are seldom at a scale large enough to detail and design surface facilities, determine earthwork designs and volumes, or to accurately measure slopes and grades. Topographic maps can be used as the base for detailed mapping if recent large-scale maps are available for the whole project area.

Digital Maps

CAD (Computer Aided Design) drawings can be very beneficial in the design and the development of operations. Drawings and maps that must frequently be updated best lend themselves to CAD systems.

Designs and drawings made on CAD systems offer a wide range of versatility. Scale can be varied easily for plotting and overlaying several different drawings. Layers can be added, hidden, or deleted from the drawing without having to regenerate the base information.

Note: Enlarging the scale on digital drawings does not increase the map accuracy. When enlarging the scale on such drawings, a reference should be made on the drawing to indicate the map scale and the accuracy of the original data.

The initial generation of a drawing using a CAD system will most likely take longer than conventional drafting methods if the entire drawing has to be created by digitizing. The advantage of the CAD system is that once the initial drawing has been generated, little effort is needed to update the drawing. The quality of the drawing is preserved because an accurate, current drawing can be plotted at any time.

A significant amount of time spent digitizing can be avoided by requesting that manuscripts from stereo plotting be provided digitally. Most mapping services can now supply complete versions of the maps in a format compatible with CAD systems.

The USGS provides a variety of cartographic, geographic, earth science, and remotely-sensed data, products, and services in support of federal, state, and public interests. These products and services include information about the Earth's natural and cultural features, base maps and special maps in several scales, digital cartographic data, aerial photographs, and other remotely-sensed data.

An example of data available in digital format is the 7.5-minute Digital Elevation Model (DEM) data files, which are digital representations of cartographic information in a raster form. DEMs consist of a sampled array of elevations for several ground positions at regularly spaced intervals. These digital cartographic/geographic data files are produced by the USGS as part of the National Mapping Program. DEM data for 7.5-minute units correspond to the USGS 7.5-minute topographic quadrangle map series for the entire United States and its territories, except Alaska. Each 7.5-minute DEM is based on 30- by 30-meter data spacing with the Universal Transverse Mercator (UTM) projection. Each 7.5- by 7.5-minute block provides the same coverage as the standard USGS 7.5-minute map series.

The federal government is in the process of developing and converting digital mapping information into a standardized format. The format used to transfer map information digitally is referred to as a spatial data format (SDF). There are many SDF formats in existence today. The Spatial Data Transfer Standard (SDTS) offers a method for standardizing the transfer of spatial data. A set of logically associated files compliant with SDTS specifications is referred to as an "SDTS transfer." The general acceptance and use of the SDTS affords many benefits, including a reduction in the software utilities required to translate data among the many formats and computer platforms. However, an initial investment of resources must be made to distribute and receive SDTS transfers. Software is required to import or export data between SDTS transfers and systems of differing formats.

More information and details regarding maps which are currently available in digital formats can be found at the USGS Mapping website at <http://mapping.usgs.gov>.

Knowing and understanding the limitations of the digital data is extremely important in creating useful and reliable maps. Incorporating and combining digital information from varying sources can lead to several problems. Map sources can be based on differing scales, coordinate systems, and accuracy standards.

Additional Map Types

Although topographic and digital maps are the most commonly used in reclamation plans, many other kinds of special maps are available for certain areas. These include maps of published soil surveys, maps of geology, maps of forest or other vegetative cover, coast and harbor charts, census maps, U.S. Postal Service maps, highway maps, and survey plats.

Selecting Mapping Scale

Maps should be at a scale and contour interval sufficient to represent the terrain, facilities, boundaries, or other features for which the map is intended. The purpose of the maps is the main consideration for map scale. The scale must be large enough to allow delineation of significant areas. A large scale increases the number of map sheets. When several drawings are necessary for coverage of a large area at a larger scale, a map index on each of the drawings should be provided to relate each drawing to the others and to place the drawing within the entire project area. Where a small area requires a larger scale for detail and accuracy, an inset of the detailed area can be placed on a map series of a different scale.

For the purpose of presentation in a set of plans or specifications, several maps scales may be needed. Selection of scale may also be a function of the intended map size. Drawings usually conform to standard sizes such as ANSI C size (17" x 22"), ANSI D Size (22" x 34"), or ANSI E Size (34" x 44"), or other standard paper size. Oversize drawings (drawings larger than "E" size) are discouraged as they become difficult to manage and reproduce. Usually, a reference map is constructed at a scale that will allow the entire project to be displayed on a single drawing.

Standard Symbols

The various mapping agencies of the United States Government have agreed on standard symbols for most cultural and natural ground features that are commonly identified on maps. Some maps show special features that are not included in the standard list. The symbols for these must be compatible with symbols used by other mapping agencies. Where cultural boundaries of different classes coincide, the symbol of the major subdivision is used. For example, where a state boundary coincides with a county boundary, the state boundary has priority.

Township and range numbers are shown along the margin sheets for all land that has been sectionalized. In a published survey, section numbers are printed in the approximate center of each section.

Maps created and used for reclamation and permitting purposes should follow the same standards when showing cultural features. All boundary lines and symbols used on the drawing should be described on the maps. This is typically accomplished using a map legend.

Mapping Accuracy

All maps should conform to National Map Accuracy Standards. These standards are well known and understood by government officials, surveyors, cartographers, aerial mapping services, and other mapmakers. Specifying National Map Accuracy Standards as a requirement for map services is an easy way to accomplish clarity and consistency of mapping results.

United States National Map Accuracy Standards

With a view to the utmost economy and expedition in producing maps which fulfill not only the broad needs for standard or principal maps, but also the reasonable particular needs of individual agencies, standards of accuracy for published maps are defined as follows:

1. Horizontal accuracy. For maps on publication scales larger than 1:20,000, not more than 10 percent of the points tested shall be in error by more than 1/30 inch, measured on the publication scale; for maps on publication scales of 1:20,000 or smaller, 1/50 inch. These limits accuracy shall apply in all cases to positions of well-defined points only. Well-defined points are those that are easily visible or recoverable on the ground, such as the following: monuments or markers, such as bench marks, property boundary monuments; intersections of roads, railroads, etc.; corners of large buildings or structures (or center points of small buildings); etc. In general what is well-defined will also be determined by what is plottable on the scale of the map within 1/100 inch. Thus while the intersection of two road or property lines meeting at right angles, would come within a sensible interpretation, identification of the intersection of such lines meeting at an acute angle would obviously not be practicable within 1/100 inch. Similarly, features not identifiable upon the ground within close limits are not to be considered as test points within limits quoted, even though their positions may be scaled closely upon the map. In this class would come timber lines, soil bound, etc.
2. Vertical accuracy, as applied to contour maps on all publication scales, shall be such that not more than 10 percent of the elevations tested shall be in error more than one-half the contour interval. In checking elevations taken from the map, the apparent vertical error may be decreased by assuming a horizontal displacement within the permissible horizontal error for a map of that scale.
3. The accuracy of any map may be tested by comparing the positions of points whose locations or elevations are shown upon it with corresponding positions as determined by surveys of a higher accuracy. Tests shall be made by the producing agency, which shall also determine which of its maps are to be tested, and the extent of such testing.
4. Published maps meeting these accuracy requirements shall note this fact in their legends, as follows: "This map complies with National Map Accuracy Standards."
5. Published maps whose errors exceed those aforesaid shall omit from their legends all mention of standard accuracy.
6. When a published map is a considerable enlargement of a map drawing (manuscript) or of a published map, that fact shall be stated in the legend. For example, "This map is an enlargement of a 1:20,000-scale map drawing," or "This map is an enlargement of a 1:24,000 scale published map."
7. To facilitate ready interchange and use of basic information for map construction among all Federal mapmaking agencies, manuscript maps and published maps, wherever economically feasible and consistent with the use to which the map is to be put, shall conform to latitude and longitude boundaries, being 15 minutes of latitude and longitude, or 7 1/2 minutes, or 3 3/4 minutes in size.

Activity Checklist

The following Activity Checklist for Contractors is not meant to be all-inclusive, nor is every item applicable to every project. A common-sense approach will achieve cost-effective pollution control.

- Check with local, state, and federal water pollution control agencies for appropriate permits and approvals prior to construction.
- Do not deviate from the approved erosion control plan without written approval of the Project Engineer.
- Place erosion and siltation control devices beside drainages, streams and wetlands before construction begins.
- Do not clear/grub to the edge of a stream unless work will begin immediately. Install silt fences between clearing of the land and grubbing operations.
- Limit grubbing or stripping to the surface area where excavation will take place within 20 days.
- Leave a 50-foot wide buffer zone of undisturbed vegetation beside waterways whenever possible.
- The construction project, if large, is staged or phased. Stabilize one phase before beginning another.
- Specify one individual who is responsible for erosion and sediment controls.
- Accomplish seeding (temporary or permanent) within 48 hours of final seedbed preparation.
- Seed a temporary seed mix upon suspension of a grading operation for more than 20 days.
- Seed all slopes having vertical heights greater than 5 feet.
- Seed temporary stockpiles of erodible materials if unused for more than 30 days.
- Check erosion and siltation control devices before, during, and after storm events and prior to weekends or holidays.
- Filter all water discharged from the construction site.
- Do not obstruct perennial, intermittent or ephemeral streams with any devices.
- Minimize entry of construction equipment into any waterway.
- Do not clean dirty equipment, especially concrete trucks, in or near waterways.
- Trench and inspect filter fabric and straw bales as conditions warrant.
- Remove sediment when it reaches one-half the height of the filter fence or, alternately, a new line of fence should be placed down slope.
- Protect stockpiled fill material with erosion and siltation control devices.
- Divert water into temporary slope drains.
- Place diversion berms and reshape as necessary to prevent runoff.
- Divert streams through a stabilized temporary diversion channel or pipe culvert before new culverts are placed.
- Do not place or discard material into waterways or wetlands.
- Do place siltation curtains (includes oil booms) in waterways prior to commencement of construction.
- Store fuel and lubricants outside of flood plains and drainage ways and as required by the Spill Prevention Control and Countermeasure Plan.
- Check erosion and siltation controls in borrow pits and waste areas weekly.

References

40 CFR 503. 1994.

Belnap, J. unpublished. Revegetation Workbook: Guidelines for Implementing Revegetation Projects, National Park Service.

Bentrup, G. and C. Hoag. 1998. The Practical Streambank Bioengineering Guide. USDA NRCS Plant Materials Center, Aberdeen, ID.

Boon, D. Y. and P. J. Smith. 1985. Carbonaceous Materials Problems Associated with Reclamation. In. Proceedings of the Second Annual Meeting of the American Society for Surface Mining and Reclamation. Denver, CO.

Cravotta, C. A., K. B. C. Brady, M. W. Smith, and R. L. Beam. 1990 Effectiveness of the Addition of Alkaline Materials at Surface Coal Mines in Preventing or Abating Acid Mine Drainage: Part 1. Geochemical Considerations. In. Mining and Reclamation Conference and Exhibition, Charleston, West Virginia.

Dunne, T. T. and L. B. Leopold, 1978. Water In environmental planning. W.H. Freeman Co., San Francisco.

Fantin, L. 1996. Clean Water with a Clear Advantage. Salt Lake Tribune.

Ferris, F. K. et. al. 1996. Handbook of Western Reclamation Techniques, University of Wyoming. DEQ.

Fisher, S. E. Jr., F. F. Munshower, and L. D. Culwell. 1989. The Potential Use of Adapted Native Plant Species In the Revegetation of Acid Spoils, Tailings, or Waste Materials. In. Proceedings: Symposium on Evolution of Abandoned Mine Land Technologies. 1989. Riverton, WY.

Franklin, W. T. et al. 1987. Salt Tolerance Study - Phase I. Summary, Conclusions, and Recommendations. Part I. Background Environmental Information. Colorado State University.

Fresquez, R.P, W. C. Lindemann and D.L. Lindsey. 1982. Soil Biota in Southwestern Coal Strip-mined Spoils. In. Reclamation of Mined Lands in the Southwest. A Symposium October 20-22, 1982. Albuquerque, New Mexico. Earl F. Aldon and Wndall R. Oaks, Eds.

Gardner, W. H. 1986. Chapter 21. In. Methods of Soil Analysis, Part 1. Physical and Mineralogical Methods. American Society of Agronomy. Monograph No. 9 (2nd Ed.)

Gould, W. L. 1982. Amendments on Sodic Spoils for Revegetation in the Southwest. In. Reclamation of Mined Lands in the Southwest. A Symposium October 20-22, 1982. Albuquerque, New Mexico. Earl F. Aldon and Wndall R. Oaks, Eds.

Haan

Haan, C. T., B. J. Barfield, and J. C. Hayes. 1994. Design Hydrology and Sedimentology for Small Catchments.

Harper, K. 1982. Soil and Environmental Manipulations to Conserve Water on Mine Spoils. Planting Guide. Native Plants, Inc. Second Annual Symposium Plant Establishment Success in Stressed Environments.

Harrelson, C. C., C. L. Rawlins and J.P. Potyondy. 1994. Stream channel reference sites: an illustrated guide to field technique. General Report No. RM-245. U. S. Department of Agriculture, Forest Service, Fort Collins, Colorado

Horton, H., Editor. 1989. Interagency Forage and Conservation Planting Guide for Utah. Extension Curricular EC433.

Kleinmann, R. L. P. and P. M. Erickson. 1983. Control of Acid Drainage from Coal Refuse Using Anionic Surfactants. USDI. Bureau of Mines Report of Investigations No. 8847.

Knighton, D. 1984. Fluvial forms and processes. Edward Arnold, London

Leopold, L. B., 1994. A view of the river. Harvard University Press, Cambridge, Massachusetts.

Mace, J.E., C. Amrhein, and J.D. Oster. 1999. Comparison of Gypsum and Sulfuric Acid for Sodic Soil Reclamation. Arid Soil Res & Rehab. 13 (2) 171-188.

McNearny, R.L. 1998. Demonstration Project for the Application of Municipal Biosolids to the Kennecott Tailings Impoundment. Annual Report. University of Utah. Department of Mining Engineering.

Morrey, D. R. 1993. Reclamation of Mining Wastes Using Stress Adapted Varieties of Plant Species. In. Intergrated Mining and Land Reclamation Planning. Reno, NV. April 5 - 8, 1993.

Nixon, M. 1959. A Study of Bankfull Discharges of Rivers in England and Wales. In Proceedings of the Institution of Civil Engineers, vol. 12 pp. 157-175.

NOAA Atlas 2, The. 1973. Precipitation Frequency Atlas of the Western United States. Volume VI. Utah.

Norman, D. K., P. Wampler, A. Throop, E. F. Schnitzer, and J. Roloff, 1996. Best Management Practices for Reclaiming Surface Mines in Washington and Oregon. Washington Dir. of Geology and Earth Resources. Report 96-2.

Norman, J. M. 1975. Design of Stable Channels with Flexible Linings. The Hydraulic Engineering Circular No.15, USDT, FHA, pp.1-136.

Phillips, C. 1996. A Manual of Good Practice for the Use of Biosolids in Land Reclamation. AMEEF Occasional Paper. No. 5. Australian Minerals & Energy Environment Foundation. Melbourne, Victoria 3000, Australia.

Pickup, G., and R. F. Warner 1976. Effects of hydrologic regime on the magnitude and frequency of dominant discharge. *Journal of Hydrology* 29:51-75.

Prichard, D. et. al., 1998. Riparian Area Management: Process for Assessing Proper Functioning Condition and Stream Channel Stability Guidelines for Range Environmental Assessments and Allotment Management Plans. Technical reference 1737-9. U.S. Department of Interior, Bureau of Land Management Service Center, Denver, Colorado. Regulatory Determination for Oil and Gas and Geothermal Exploration and Production Wastes. 1988. 53 Federal Register 25446-25459.

Roberts, B. 1995. Best Management Practices for Erosion and Sediment Control, Eastern Federal Lands Highway Design, Federal Highway Administration, Report No. FHWA-FLP-94-005.

Schumm S. A. 1960. The shape of alluvial channels in relation to sediment type. U.S. Geological Survey Professional Paper 352-B. U.S. Geological Survey.

Schmitz, M., 1999. Biosolids Management Program Coordinator, DEQ, personal communication.

Searcy, 1967. The Hydraulic Engineering Circular No.11, Use of Riprap for Bank Protection.

Simons, D.B., and F. Senturk 1977. Sediment transport technology. Water Resources Publications, Fort Collins, Colorado.

Simons, L, and Associates 1982. Surface Mining Water Diversion Design Manual. OSM/TR-82/2, United States Department of the Interior, Office of Surface Mining.

Skousen, J. 1991. Anoxic Limestone Drains for Acid Mine Drainage Treatment. *Green Lands* 21(4):30-35.

Skousen, J. and G. Larew. 1991. Alkaline Addition to Prevent Acid Mine Drainage: A Field Example. *Green Lands*:32-35.

Skousen, J. and J. Sencindiver. 1988. The Latest Word on Wetlands. *Green Lands*: 25-27.

Slick, B. M. and W. Curtis. 1985. A Guide for the Use of Organic Materials As Mulches in Reclamation of Coal Minesoils in the Eastern United States. United States Department of Agriculture, Forest Service, General Technical Report NE - 98. 144p.

Sobek, A.A., W.A. Schuller, J.R. Freeman, and R.M. Smith. 1978. Field and Laboratory Methods Applicable to Overburdens and Minesoils. EPA 600/2-78-054.

Soil Conservation Service, 1977. Design of Open Channels. Technical Release No.25.

Thornburg, A. A., 1982. Plant Materials for Use on Surface-Mined Lands in Arid and Semi-Arid Regions, USDA, SCS.

Toy T. J. and G. R. Foster. 1998. Guidelines for the Use of the Revised Universal Soil Loss Equation (RUSLE) ver 1.06 on Mined Lands, Construction Sites, and Reclaimed Lands. Office of Surface Mining. Western Regional Coordinating Center.

USDA. R-4 Reclamation Field Guide, Minerals Management, USDA Forest Service, Ogden, UT.

USDA. Salinity Laboratory. 1954. Agricultural Handbook #60.

USDA-NRCS. 1993. National Soils Handbook. Title 430.

USDA. Soil Survey Staff. 1993. Soil Survey Manual. Handbook No. 18.

USDA-NRCS. Soil Survey Staff. 1998. Keys to Soil Taxonomy, 7th ed.

U.S. Environmental Protection Agency, Cincinnati, Ohio. Methods 3.2.3 and Method 3.2.4.

Wasser, C. H. 1982. Ecology and Culture of Selected Species Useful in Revegetating Disturbed Lands in the West. U.S.D.I. Fish and Wildlife Service, Office of Biological Services, Western Energy and Land Use Team. FWS/OBS-82/56.

Waugh, W. J., M. E. Thiede, D. J. Bates, L. L. Cadwell, G. W. Gee, and C. J. Kemp. 1994. Plant and Environment Interactions Plant Cover and Water Balance in Gravel Admixtures at an Arid Water-Burial Site. *J. Environmental Quality*. 23:676-685. 676-685p.

Wham, D. 1993. Unpublished. State of Utah Nonpoint Source Best Management Practices for Mining Operations, Department of Environmental Quality, Division of Water Quality.

Williams and Schuman. 1987. Reclaiming Mine Soils and Overburden in the Western United States, Analytical Parameters and Procedures. Soil Conservation Society of America. pp.111-113.

Wolman, M.G. and J.P. Miller. 1960. Magnitude and frequency of forces in geomorphic process. *Journal of Geology* 68: 54-74.

Wolman, M.G. and L. B. Leopold 1957. River flood plains: some observations on their formation. USGS Professional Paper 282C.

Woodyer, K.D. 1968. Bankfull frequency in rivers. *Journal of Hydrology* 6:114 - 142.